

# Experimental Analysis of the Axially Compressed Metal Tubes and its Energy Absorption Capacity

Pradeepa Kumar Mohanty<sup>1</sup>, Asutosh Pati<sup>2</sup>, Jyotirmay Swain<sup>3</sup>

<sup>1</sup>, <sup>2</sup>Asst. Professor, <sup>3</sup>Student

Department of Mechanical Engineering  
Einstein Academy of Technology and Management  
Bhubaneswar, Khurdha  
Odisha, India

## ABSTRACT

Impact energy absorbers are used to dissipate the kinetic energy in the event of an unwanted collision. This used as mechanical fuses to limit the loads. This also may act on the main structure immediately after a collision. Aluminum tubes and tubular structures are used as impact energy absorbers in different engineering applications. These are available in different cross sections and sizes. This is also has high energy absorption capacity under quasi-static and dynamic loads. In this paper, experiments are conducted on circular aluminum tubes under quasi-static, axial compression. The different modes of deformation of these tubes are examined in two separate cases. Efficient mode of deformation is examined using dies of different radii. The energy absorption capacity under quasi-static loading conditions is evaluated in the both cases to evaluate the energy absorption capacity. The energy absorption of aluminum tubes are compared based on the different deformation modes. The results in this paper are useful in the design of impact energy absorbers.

**Keywords:** Dynamic loads, Energy absorbers, aluminum tubes, quasi-static, flat platens, load-displacement curves Introduction.

## 1. INTRODUCTION

The major challenge in the design of impact energy absorbers (IEA) is to establish the relation between the specified force level to the geometric and material properties of the impact energy absorber.

The selection of an appropriate energy absorber depends very much on its application and the desired response upon impact. So, for an IEA to perform effectively it should possess the following qualities:

- Undergo large plastic deformations at controlled rates.
- A predictable flat load-deformation characteristic under quasi-static and dynamic loading conditions.
- High specific energy absorbing capacity (energy absorbed per unit mass). This makes it ideally suitable for applications in automobile and aircraft industries.
- High energy-dissipation density (or energy absorbed per unit volume). This is required as for protective cladding sin static structures or to absorb the kinetic energy of a falling lift.

### 1.1. Aluminium Tubes as Impact Energy Absorbers

Circular tubes are used extensively as energy absorbing elements, the main attraction

being their ready availability in a wide range of dimensions and materials as well as the wide range of deformation modes which can be generated. Depending upon the mode of deformation, it is possible to obtain behavior ranging from low force-long stroke characteristic to a high force -short stroke characteristic from the same tube.

Basically tubes can be subjected to diametral (or lateral) compression or axial compression. The lateral compression modes which produce the relatively low force-long stroke formation characteristics have been reviewed by Reid et al [1] and a particularly efficient variant of this mode has been described by Reid et al. [2]. With regard to axial compression, the tube may be subjected to compression between two flat plates or between a flat plate and a shaped die. In the former case, which has been studied by many authors, the tube deforms by progressive buckling in an ax-symmetric, fold patterns [3].

Stronge et al. [4, 5] have examined the behavior of square-sectioned tubes pressed on to a shaped die. Fractures are initiated at the corners and cracks propagate along the edges of the tube while the flat strips so formed curl up as the compression continues. It was observed that such an energy absorbing device has a long stroke and operates at a load which increases mildly as the deformation progresses.

## **1.2. Aluminium Tube under Axial Compression**

The behaviour of an axially compressed tube depends on the end fixtures provided. For example a tube may be fixed at both its ends; or it may be provided simply supported conditions by placing the tubes in suitable grooves; or it may be compressed between two flat plates; or it may be compressed between two shaped die fixtures; and any combinations of the above are possible. Tubes crushed under axially applied loads through two flat plates show a progressive plastic folding behaviour. The end conditions of the tube only affect their behavior during the first part of the crush displacement. One of the earliest analyses to be done on the buckling of the thin walled cylinders was presented by Alexander in 1960. The main objectives of Alexander's [6] work were to predict the necessary dimensions for cylindrical shell that were to be used as energy absorbers in the vertical fuel channels of nuclear reactors. He proposed a model of collapse, as shown in Figure 1, in which a general fold other than the one near the edge consisted of two straight-sided convolutions by virtue of the simultaneous formation of three fully plastic circumferential hinges (A, B and C). The following are the assumptions made in Alexander's model are as follows:

- The tube material was assumed to be rigid perfectly-plastic, hence ignoring all elastic and strain hardening effects.
- The deformation process was governed by the Von-Mises yield criterion.
- The value of the material yield stress in both tension and compression are equal.
- The material is deforming under plain strain conditions.
- The folds are formed in sequence one at a time and are either fully outward or fully inward with respect to the original tube wall.

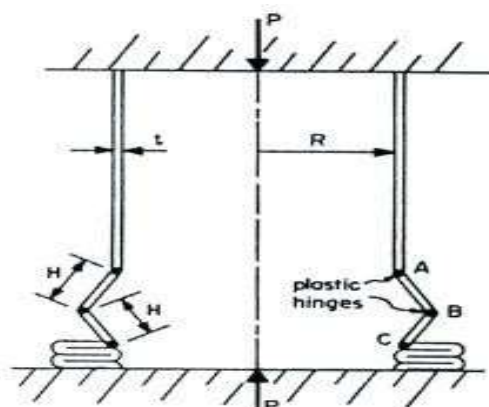

## **2. METAL TUBES FOR IMPACT ENERGY ABSORPTION: A BRIEF LITERATURE REVIEW**

Reddy et al [7] have studied the behavior of thin sheet metal tubes for empty and wood filled conditions. They have analysed and suggested a deformation mechanism for progressive crushing of wood filled tube. The results of the idealized model is then compared with the experimental results and found areas on able agreement.

Reddy and Reid [8] developed the relationship between the dynamic and quasi-static load-deformation characteristics of thin-walled metal tubes compressed laterally between rigid plates was explored with reference to the use of such tubes in impact energy absorbing systems. The resulting formulation is used as the basis for obtaining the results on mild steel and aluminium tubes of the same nominal dimensions.

Hanssen et al [9] have showed that, the energy absorption in the crash boxes was not affected when global bending effects occurred during the crushing process.

Reddy T. Y and Reid S. R [10] have studied that the tubes splits into number of axial cracks from the initiated cracks resulting in strips due to bending and curling. They have compared with a simple analytical approach and the splitting tube device has the advantage of a flat load deflection characteristic and operates successfully with a wide range of tube properties and tube and dies geometries.

Johnson and Reid [11] have studied the buckling of circular cylinder shell under axial load is classical problem in solid mechanics particularly in the plastic region under both static and dynamic conditions. From the point of view of energy absorption capacity and available stroke length, it has been found that circular tubes under axial compression to provide one.

### **2.1. Metal tubes for impact energy absorption: A brief literature review**

Reddy et al [7] have studied the behavior of thin sheet metal tubes for empty and wood filled conditions. They have analysed and suggested a deformation mechanism for progressive crushing of wood filled tube. The results of the idealized model is then compared with the experimental results and found a reasonable agreement.

Reddy and Reid [8] developed the relationship between the dynamic and quasi-static load-deformation characteristics of thin-walled metal tubes compressed laterally between rigid plates was explored with reference to the use of such tubes in impact energy absorbing systems. The resulting formulation is used as the basis for obtaining the results on mild steel and aluminium tubes of the same nominal dimensions.

Hanssen et al [9] have showed that, the energy absorption in the crash boxes was not affected when global bending effects occurred during the crushing process.

Reddy T.Y and Reid S.R [10] have studied that the tubes splits into number of axial cracks from the initiated cracks resulting in strips due to bending and curling. They have compared with a simple analytical approach and the splitting tube device has the advantage of a flat load deflection characteristic and operates successfully with a wide range of tube properties and tube and dies geometries.

Johnson and Reid [11] have studied the buckling of circular cylinder shell under axial load is classical problem in solid mechanics particularly in the plastic region under both static and dynamic conditions. From the point of view of energy absorption capacity and available

stroke length, it has been found that circular tubes under axial compression to provide one of the best devices. Alexander [12] gave a rigid plastic analysis for axisymmetric plastic buckling of a tube of certain diameter and thickness. Johnson, Soden and Al-Hassani [6] have considered an essentially in extensional mode of deformation and calculated the corresponding mean collapse load. In terms of the behavior of tubes of various cross-sectional shapes, circular ones are unique in having essentially the same mode of deformation in both static and dynamic compression. Deformation is mainly concentrated at the end of the circular tube which is impulsively loaded.

### 3. SPECIMEN PREPARATION FOR EXPERIMENTAL STUDY

Specimens of circular aluminum tubes were cut to a length of 150 mm from the stock as received from the market. The ends of the tubes were finished to close flat surfaces by turning the tubes in the lathe machine and the ends were finally grounded. Thus the tubes have an aspect ratio (l/d) of 3. The surfaces of the tubes were inspected for any imperfection and cleaned with kerosene.

**Table 1** Co-ordinates of contour nozzle Properties of tube materials and specimen dimensions

Specimen	Property	Value	Specimen dimensions (mm)
Aluminium 6063	Density	2700kg/m <sup>3</sup>	Outer Diameter – 50.8 Thickness – 1.60 Length – 150
	Modulus of Elasticity	69.5GPa	
	Melting Point	600 °C	
	Min. Tensile Strength	100 MPa	
	Shear Strength	70MPa	
	Vickers Hardness Number	70	

#### 3.1. Die Preparation

The die was formed by turning a mild steel rod of diameter 82 mm in lathe machine. The different dies of radii 4mm, 6mm and 10 mm were prepared. These formed dies hardened in a heat treatment furnace. Brinell hardness test was then conducted on the formed die to evaluate the hardness of the material which was found to be 400 BHN. Table-2 gives the details of the die material properties and geometry.

**Table 2:** Die material properties and geometry

Material	Outer dia. D (mm)	Shank dia D (mm)	Shank length L (mm)	Die fillet radius R (mm)	Property	Value
EN8 Mild Steel	82.57	47.3	10	R <sub>1</sub> =4 R <sub>2</sub> =6 R <sub>3</sub> =10	Ult Stress	1200 MPa
					Yield Stress	698 MPa
					BHN	400

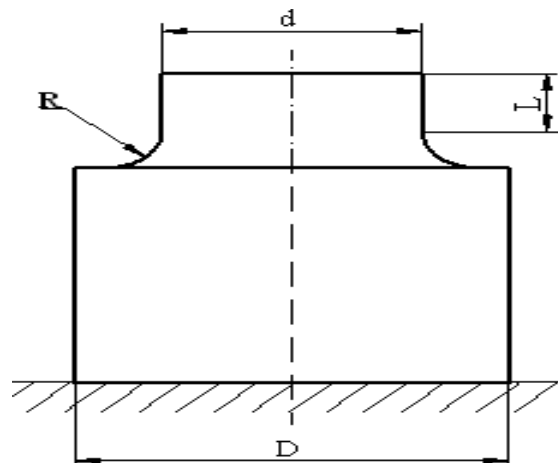

Figure 2: the geometry of the formed die

Uni-directional, quasi-static compression tests were carried out on metal tubes using electronic universal testing machine of 400 kN capacity (UTES-40) at a constant compression rate of 10 mm per minute. Fig.2 shows the test equipment.

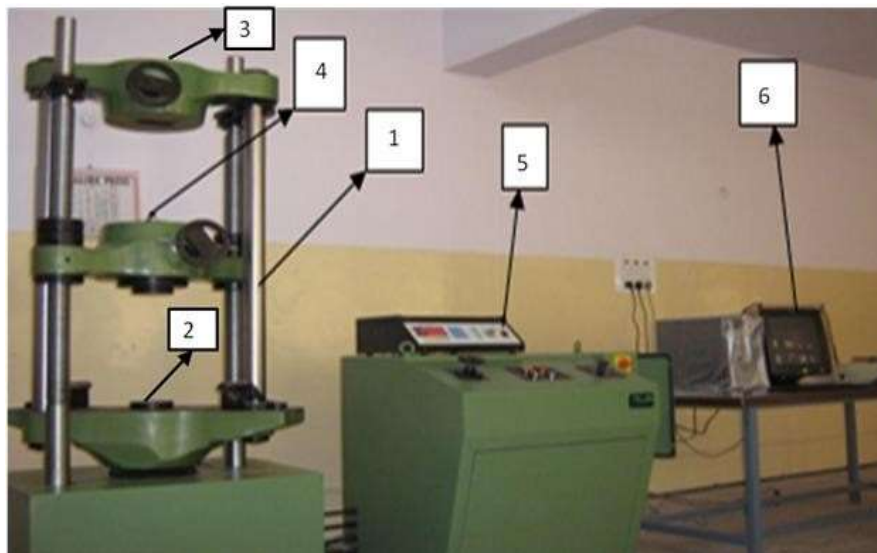

Figure 3: Electronic universal testing machine

- 1) Machine frame
- 2) Bottom beam
- 3) Top beam
- 4) Middle cross head
- 5) servo control unit
- 6) Computer control

Figure 3 shows the schematic of the test set-up. All the specimens were compressed axially. It consists of a die with a radius,  $R$  resting on a rigid bottom beam and shows a tube which has been introduced on to the die shank. The middle cross head pressed the tube on to the die at a constant compression rate in the quasi-static test.

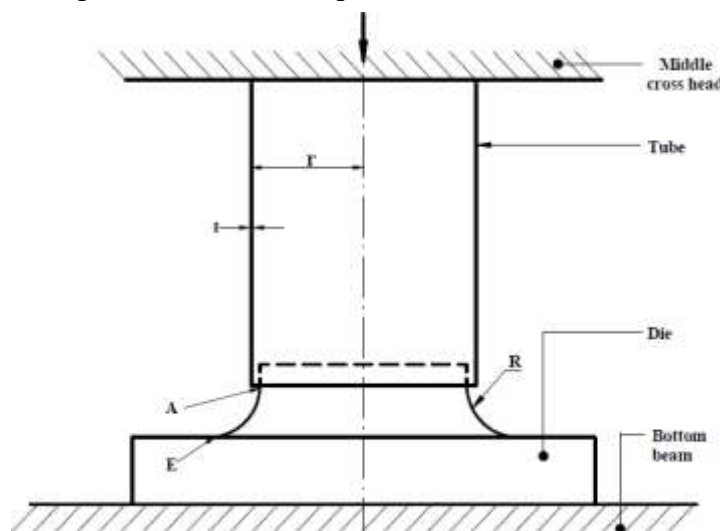

Figure4 Schematic of the test set up

## 4. EXPERIMENTAL STUDY ANALYSIS

### 4.1. Quasi-static uni-directional compression of aluminium tubes between a flat platen and shaped die of radius of 4 mm

As the specimen with vertically induced cracks loaded in compression, it shows the initial

elastic response which is indicated by the rise in load (a-b) in the figure 5

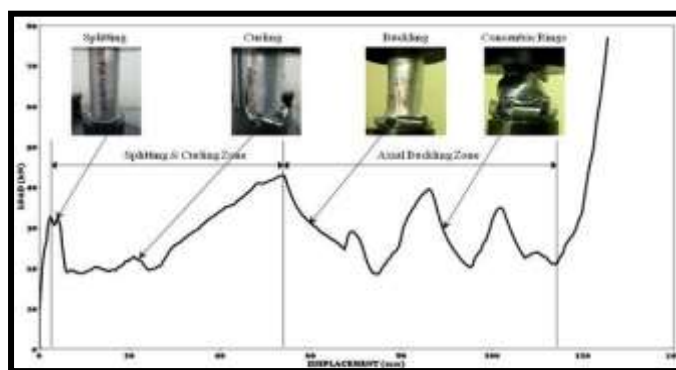

Figure 5 Typical load-displacement curve when aluminium tube compressed under quasi static loading condition (4mm)

For the die radius of 4mm, it is witnessed that the deformation of the tubes involves splitting, curling and folding modes.

#### 4.2. Load-displacement response for aluminium tubes of die radius of 4 mm

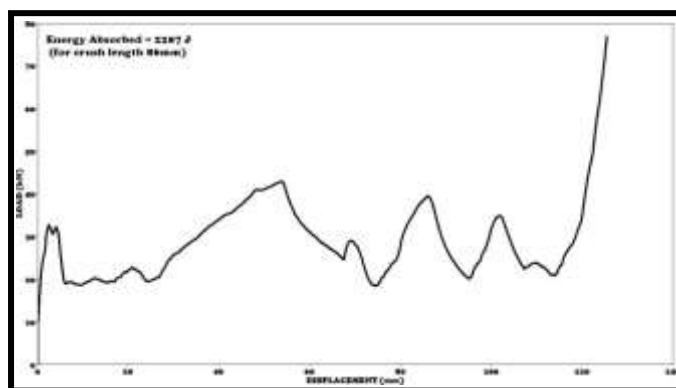
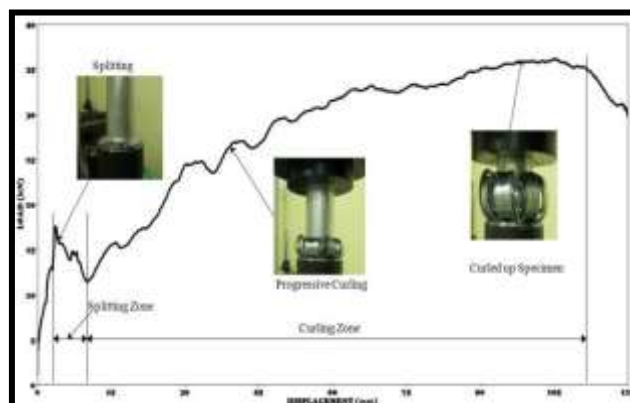

Figure6 Load-displacement curve for the aluminium tube specimen (4mm)

Figure 6 shows load-displacement curve for the aluminium tube specimen which shows energy absorption for the crushed length of 80 mm.

#### 4.3. Quasi-static uni-directional compression of aluminium tubes between a flat platen and shaped die of radius of 6mm

Figure 7 shows the typical load deformation response of the aluminium tube with vertical cracks induced at the bottom face of the tube. The tube pressed on to a shaped die of radius 6mm. For the die radius of 6 mm, it is witnessed that the deformation of the tubes involves splitting and progressive curling modes.



**Figure 7** Typical load-displacement curve when aluminium tube compressed under quasi static loading condition (6 mm)

#### 4.4. Load-displacement response for aluminium tubes of die radius of 6 mm

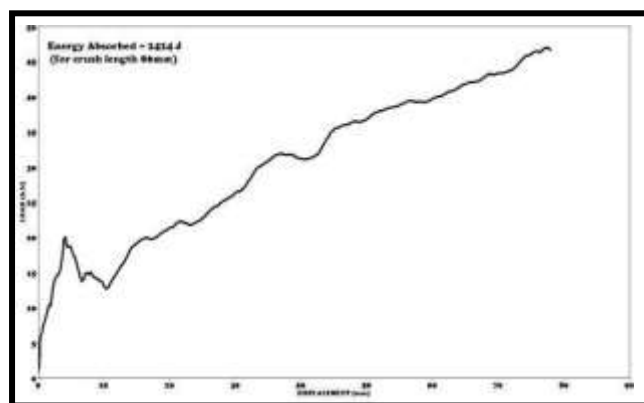
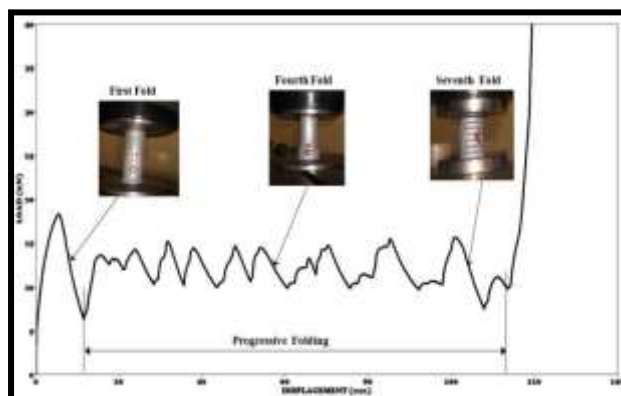

**Figure 8** Load-displacement curve for the aluminium tube specimen (6mm)

Figure.8 shows load-displacement curve for the aluminium tube specimen which shows energy absorption for the crushed length of 80 mm.

#### 4.5. Quasi-static uni-directional compression of aluminium tubes between two flat platens

Figure.9 shows the typical load deformation response of the aluminium tube along with specimen at specified stages of compression.



**Figure 9** Typical Load-displacement curve when the aluminium tube compressed under quasi-static loading condition.

#### 4.6. Load-Displacement response for aluminium tubes compressed axially between two flat platens

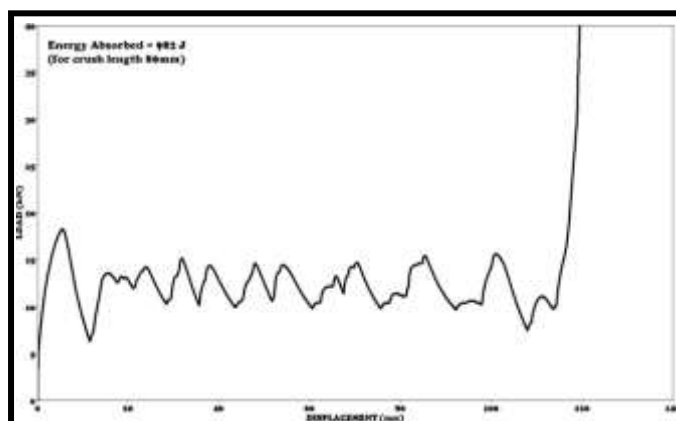



**Figure10** Load-displacement curve for the aluminium tube specimen

It is observed that the deformation of the tube involves subsequent folding modes. The experimental results on circular aluminium tubes subjected to axial compressive loading under quasi-static loading conditions when compressed between a flat platen with two different shaped radii die of 4 mm and 6 mm and compressed between two flat platens. The energy absorbed by the aluminium tubes compressed under the above loading conditions is calculated as are under load-displacement curves.

The average energy absorption by the aluminium tubes with induced vertical cracks for the die radius of 4 mm and 6 mm was nearly same about 2.5 kJ. The average energy absorbed by the circular aluminium tubes when compressed between the flat platens is found to be 2.7kJ.

The deformation modes observed during the tests on 4 mm die radius was due to the splitting, curling and folding mechanisms. In this, the curled up strip offer more resistance to the plastic deformation of material. Where as in the tests conducted on specimen using the die radii of 6 mm, the modes of deformation were splitting and curling only. Therefore the energy absorption during the plastic deformation is less compared to 4 mm die radius. Though the energy absorption during the compression of 4mm die radius is more, the total deformation pattern was irregular and unpredictable. Whereas the deformation modes observed during the compression using 6 mm die radii and between two flat platens were regular, repeatable. Therefore the total plastic deformation of tubes was nearly predictable.

## **5. CONCLUSIONS**

An energy absorber is a system that converts, totally or partially, kinetic energy into another form of energy. Energy converted is either reversible, like strain energy in solids, or irreversible like plastic deformation energy.

The present paper shows the following conclusions from the experimental work carried out on circular aluminium tubes compressed under quasi-static loading conditions for energy absorption capacity and deformation modes.

From the experimental studies, the deformation modes of aluminium tubes depend on the shape/geometry of the end supports between which they are loaded under compression. It is observed that loading between the shaped die and a flat platen results in splitting, curling, where as it is the folding mode of deformation when loaded between two flat platens. Axial buckling observed as the efficient mode of deformation and the folding mode gives a predictable deformation patterns which is a desirable requirement of an impact energy absorber.

## **REFERENCES**

- [1] S.R.Reid, "*Laterally compressed tubes as impact energy absorbers*", Structural crashworthiness, (Edited by N. JONES and T. WIERZBICKI), Butterworth's, London (1983), pp.1-43.
- [2] S. R. Reid, C. D. Austin and R. Smith, "*Tubular rings as impact energy absorbers*", Structural impact and crash worthiness, volume 2 (Edited by J.MORTON), Elsevier, London (1984). pp. 555-563.
- [3] W. Abramowicz And N. Jones, "*Dynamic axial crushing of circular tubes*". Int. J. Impact. Engg 2, 263 (1984)
- [4] W.J.STRONGE, T.X.Yu and W. JOHNSON, "*Long stroke energy dissipation in splitting tubes*". Int.J. Mech. Sci. 25637 (1983)

- [5] W.J.STRONGE, T.X.Yu and W.JOHNSON, “*Energy dissipation by curling tubes*”. *Structural impact and crashworthiness*, Vol. 2 (Edited by J. MORTON), Elsevier, London(1984),pp. 576-587.
- [6] Johnson, Soden and Al-Hassani, “*Inextensional collapse of thin walled tubes under axial compression*”, *J. Strain Anal.*Vol12,pp317(1977)
- [7] Reddy T Y and Al-Hassani S T S., “*Axial crushing of wood filled square metal tubes*”, *Int J Mech Sci.*,Vol. 35(1993)pp231-246.
- [8] Reid S R and Reddy T Y, “*Effects of strain rate on the dynamic lateral compression of tubes*”,*Inst.Phys.Conf.Ser.No.47*, Cambridge, UK(1979)
- [9] Hanssen A G, Lorenzi K K, Berger O S and M Langseth, “*A demonstrator bumper system based on aluminum foam filled crash boxes*”, *Int Journal Crash worthiness*, Vol.5, part-2,pp1-11(2000)
- [10] T Y Reddy and S R Reid, “*Axial splitting of circular metal tubes*”, *Int. J. Mech. Sci.*Vol.28, No. 2,(1986), pp. 111-131.
- [11] W. Johnson and S R Reid, “*Metallic energy dissipating systems*”, *Applied Mechanics Reviews*,Vol. 31, (March 1978), pp277-288.
- [12] Alexander J M, “*An approximate analysis of the collapse of thin cylindrical shells under axial loading*”,*J. Mech. Appl. Mech.*, XIII,(1960), pp1-10.
- [13] Dr. M.Tamil Selvi, D.Yuvaraj, Dr.A.K. Dasarathy, S.Ponkumarelango and R.Subalakshmi, Assessment of Energy Absorption of Steel, Polypropylene and Hybrid Fiber Reinforced Concrete Prisms Using-Graph Software,*International Journal of Civil Engineering and Technology*, 8(10), 2017, pp.1269–1276.