

Recommendations and a Case Study for Creating a Large-Scale Electrostatic Charge Control Strategy

^{1*} Dr.Srinivas Mantha, ² Mrs.Rosy Satapathy
^{1*} Professor, Dept. Of Electrical Engineering, NIT BBSR,
Asst. Professor DEPT. of Electrical Engineering, NIT BBSR,
srinivasmantha@thenalanda.com, rosy@thenalanda.com

Abstract

Large-scale scientific instruments strongly support top-level research all around the world. Besides their intrinsic merits, they often play a valuable role as pathfinders for developing and testing instrumentation and as training grounds for young researchers. Strategies and roadmaps for these facilities have become a priority for a number of private and public funding organizations. Despite the large amount of mature work done in the industrial arena, it is difficult to find documents providing clear and concise orientation on how to prevent or minimize the damage caused by electrostatic discharges (ESD) in research infrastructure. This paper aims to gather all this information to develop a static charge control plan for a large-scale scientific facility. The specific case of the static charge control plan for the installation of CTA-LST telescopes is added as an example and verification of the actual applicability of the measures proposed in this document, providing static charge in human body monitoring measurements. Specific tests performed on equipment with ESD sensitive components are also described, which helped to assess any possible damage.

Keywords

Static Charge, Cherenkov Telescope Array, Research Infrastructures

1. Introduction

The definition of electrostatic charge is an electric charge at rest. Static electricity is an imbalance of electrical charges within or on the surface of a material. This produces a measurable electric field that can influence other objects. It is principally generated by Triboelectric Effect, which takes place when two surfaces with no charge at the first moment, establish contact and then separate from each

other, becoming charged. There are also other ways like field induction, direct contact and ion bombardment [1].

An electrostatic discharge (ESD) is the rapid and spontaneous transfer of electrostatic charges induced by a high electrostatic field. It is small lightning generated between the two surfaces, which could only take place when the difference in voltages is as high as a dielectric

breakdown could occur [2].

A clear case of this type of discharge is indeed a lightning strike. But a few others, more frequent events produce strong ESD. For instance, there is the simple fact of touching a doorknocker or walking with common footwear.

A person can feel this kind of discharge if the voltage is above 2 - 3 kV, and the spark can be seen if it is above 7.5 kV [3]. But an ESD can change the electrical characteristics of a semiconductor device and damage it even until its complete destruction, in some cases, just with 100 V.

Electronic devices can be classified according to their robustness to ESD. The most sensitive ones are called 'ESDS Components' (Electrostatic Discharge Sensitive Components). ESDS is defined as the lowest ESD level that causes changes in the device characteristics such that the component no longer complies with its nominal specifications. High-speed semiconductor devices and high-density microchips are typical examples of ESDS. As an example, the ESD susceptibility of CMOS is 250 - 3000 V and MOSFET is 100 - 200 V.

The failures caused can be catastrophic (producing permanent and irreversible damage) or latent (the device still works but its lifetime is reduced, or some functions are affected). This second type of failure is hardly detectable because components might pass the tests but the effects appear when they are already installed in the final system [4].

ESD damage can be caused by an electrostatic discharge to a device (simulated by Human Body Model, HBM), an ESD from a device (simulated by Charged Device Model, CDM) or by field-induced discharges. The human body is one of the most important places where the charges can be accumulated. In some common activities such as walking across a carpet or over another floor that is not ESD protected, human body can accumulate an electrostatic voltage between 250 V and 35,000 V. Those values are high enough to damage most electronic devices. For that reason, it is important to have an ESD control program.

The design of a static charge control plan starts with the definition of the roles and personnel in charge within the collaboration team. There must be a manager who oversees distributing the tasks according to the different objectives of the plan in order to coordinate the verification of the standards. The manager should, depending on the complexity of the installation, either be assisted by independent delegates with suitable expertise in static charge or interact directly with the production engineers.

The static charge control plan will mainly consist of two fundamental parts: the ESD control in laboratories and environment and the ESD control in products, both external and custom-made. It is also necessary to perform periodical deliverables in which information is provided as a technical report of the measures that have already been taken and the procedures that still need to be fulfilled. These documents will be associated with

each part of the plan.

This paper aims to describe how a static charge control plan must be developed for a large-scale scientific installation, providing the guidelines to control ESD in the prototyping laboratories, the site of the installation and the critical products. In order to better understand how this plan is implemented in practice we explain a case study where a plan following the ideas described here is developed and put into practice: The Large Size Telescopes of the Cherenkov Telescope Array (CTA-LST).

This paper has been structured according to the two major parts that we have spotted as main building blocks in a static charge control plan. The first block is covered in Section 2, where we describe ESD control in laboratories and environments. The second block focused on products, is described in Section 3. The last section is devoted to explaining the case study.

2. ESD Control in Laboratories and Environment

General Remarks

The EOS/ESD Association offers general guidelines that are helpful to decide which actions must be taken to control static charge in working places and laboratories [5]. Additional references on specific tests are also available [6] [7]. There are six key concepts for an ESD control program:

1) **Design in protection.** It is important to design devices and equipment resistant to the effects of ESD, using less sensitive items and providing protections.

2) **Determine the level of control needed.** It is necessary to know the most susceptible and sensitive devices and the values of the withstand voltages of them. Valuable guidelines can be found in ANSI/ESD S20.20 [4] and IEC 61340-5-1 [8] standards. It is accepted that if one can control three essential items, namely grounding, working on anti-static surfaces and using anti-static packaging, then it is possible to efficiently prevent discharges above 500 V. To provide security to devices with sensitivity over 100 V, it is necessary to apply the Basic Control Program shown in the standards. If devices with lower sensitivities are handled, advanced control is needed with more stringent technical requirements and the periodicity of verifications must be increased. It is compulsory to know and report the HBM ratings of most sensitive devices.

3) **Identify and establish the electrostatic protected areas (EPA).** These areas are places where the implementation of basic ESD control methods is required.

4) **Decrease the generation and accumulation of electrostatic charge.** It is mandatory to remove all unnecessary materials and processes that could generate or accumulate charge, such as insulators or mobile items. Conductive and dissipative materials, including people, must be connected to ground whenever possible. The ANSI/ESD S6.1-2005 standard provides helpful information on ESD control grounding procedures to use within an EPA for protection of ESD sus-

ceptible items [9]. The criteria to establish suitable ESD bonding is also provided.

5) **Dissipate and neutralize.** Electronic ionizers must be used to neutralize the excess of electrostatic charge in those EPA places where the use of insulators or mobile items cannot be avoided, and in general in those where static charge accumulations are foreseen.

6) **Protect the products.** Transport and storage of ESD sensitive devices must be carried out in antistatic bags. This way, the elements inside the bag are protected from getting charged or discharged because of the movement of the product inside it. This should be done when the devices are in or out of an EPA.

Laboratories and Site

It is necessary to identify the places where the static charge control plan applies. It will be classified in:

- o Environment;
- o Integration and test laboratories;
- o Design and prototyping laboratories.

Environment shall be reviewed to identify any possible place for static charge accumulation. In addition, resistivity and ground resistances shall be checked.

It is assumed that in integration and test laboratory there is no direct contact with electronics at component level. The accessible items are supposed to be tested at system level so in general, they are expected to withstand voltages between 4 kV and 15 kV. Therefore, basic control is accepted. In this case, the use of common shoes is allowed, but it is advisable to use anti-static footwear or a special floor.

However, design laboratories are environments for microelectronics fabrication, circuit board assembly, manufacturing test and repair of electronics, among others, so they must be controlled environments in order to guarantee the protection of sensitive devices. Thus, it is mandatory to implement a basic ESD control program that meets the demands of the standard IEC 61340-5-1 [8] or ANSI/ESD S20.20 [4]. This can be summarized in two major requirements:

1) Workers at the laboratory have received suitable training to control static charge or are always working with a trained engineer.

2) The laboratory uses an EPA with the specifications detailed below for any kind of manipulation of a product or any of its parts [10].

The main elements of the basic control are detailed below:

Grounding: The ground system must be regularly evaluated. It could be a known ground or a virtual one. The key factor is that all the materials, including people and auxiliary grounds, must be connected to the same point, called “common ground point” in order to have the same potential. In the standard ANSI/ESD S6.1—Grounding of the ESD Association [9] there is a two step pro-

cedure for grounding. If the installation does not have any access to the AC ground it is necessary to establish an equipotential bond, which ensures that all the elements are going to be at the same potential, even if it is not ground.

Wrist strap: It is the most common protection measure to connect people to ground whose use is regulated in the standard ANSI/ESD S1.1—Wrist Straps [11].

To make this connection it is important to remember that the human body is being exposed to 250 V AC. A resistance that limits the current to 0.25 mA is needed in order to avoid hazards. Following Ohm's Law, the resistance needed is 1 M Ω . This resistor is usually included in the security packs that contain the wrist straps.

Working surface mat: The principal objective is to provide a surface free of static charge connecting it to ground and, thus, a place to remove charges from the objects and materials that are placed on this surface. For electronic applications, this surface should have a ground resistance between 10⁶ and 10⁹ Ω . All the information is available in the standards ANSI/ESD-S4.1: Worksurfaces-Resistance Measurements [12] and ANSI/ESD S4.2: Worksurfaces—Charge Dissipation Characteristics [13].

ESD floor: It must be static-dissipative and thus, there is a reduction in the accumulation of charge. This way, workers and the rest of the elements presented in the EPA are ESD protected. In the case of mobile elements, it is important that they are equipped with dissipative or conductive wheels making electrical contact with the floor [14]. If there is no possibility of installing an ESD floor, there are mats that work as anti-static surfaces. The floor resistance must be between 10⁵ and 10⁸ Ω [15].

Footwear system: As an alternative to the wrist strap, when the worker is stand up or moving, there are some accessories for common footwear like anti-static heel conductors or ribbons, that perform the same function that anti-static shoes. Perspiration is also important because it allows the lack of necessity of direct contact between the accessory and the skin. The combination with an ESD floor is desirable, providing a safe path to dissipate charges, but it is not recommended to get out of the EPA with protection shoes because it could bring dirt that acts as isolator and accumulates charge [16] [17]. The procedure for verification tests is in the standard ANSI/ESD-S9.2: Footwear-Footgrounders Resistive Characterization [18].

ESD clothing and gloves: It is something to consider especially in clean rooms or environments with very low relative humidity. Anti-static clothes must not be insulators and, consequently, sources of charge [19]. Their use is explained in the standard ANSI/ESD STM2.1: Garments-Characterization [20].

As regards gloves, they could only be anti-static (conductive) or made of cotton. The standard that collects the use and test of gloves and finger coats is ANSI/ESD SP15.1: In-Use Resistance Testing of Gloves and Finger Coats [21].

Reduction of the static charge: It is impossible to eliminate the charge at all. There are some

chemical anti-static solutions but, according to standard JEDEC: JESD625-4 [22], they must be correctly chosen. The process has to be repeated regularly and the product cannot be applied directly to the sensitive devices or when they are in the area.

On the other hand, there are ionizers that provide positive and negative charges that are distributed in order to discharge insulator materials by neutralizing electrical charges in those materials. We have to use ionizers when the presence of insulating materials cannot be avoided and in areas where the application of chemical solutions is not viable, and they must cover the whole working area. Their use is standardized in ANSI/ESD STM3.1: Ionization [23].

It is also important to consider the use of humidifiers. Low relative humidity increases the ESD. Thus, inside the EPA you could use a humidifier aiming in the control of this parameter that will decrease the ESD events. Following the standard JEDEC: JESD625-A [22] relative humidity must be higher than 30% and preferably, higher than 40%.

Packaging and transport: It must guarantee the security of the devices out of the EPA. The transport of sensitive components is only permitted in anti-static bags that must isolate the material against direct ESD, possible Triboelectric Effect and electrostatic fields. There are some types of bags depending on their resistance and protection level. This is standardized in ANSI/ESD S541: Packaging Materials for ESD Sensitive Devices [24].

Identification: The appropriated symbols must be used to identify the elements that are sensitive to ESD, shown in the standard ANSI/ESD S8.1—ESD Awareness Symbols [25].

Monitoring: If possible, it is recommendable to monitor in real time the voltages and ground resistors to probe the correct function of the connections, especially, the connection of wrist-straps and working surfaces. It is also possible to use an electrostatic voltmeter or field-meter to provide accurate non-contacting measurements of the electrostatic surface voltage or field. The electrostatic field-meters are indicated for measurements in preferably large surfaces, due to its operating principle and their results are voltages dependents on distance, while electrostatic voltmeters can be used to take measurements in small surfaces and in some cases, have an option that enables one to monitor the charge values, for example, from a person walking.

Periodical inspections: It is essential to perform periodical checks to ensure that all the elements work correctly. The information about the procedure to verify the correct working of the components of an EPA can be found in the technical report TR53-01-06 [26].

3. ESD Control in Products

Sensitivity Tests and Applicable Standards

To qualify the devices and systems design in own laboratories, there are sensitivity tests that determine the maximum level the device can withstand. In terms of “off the shelf” electronics, they should have been tested and classified the same way, in order to know if some additional security

measures have to be taken. If they have not passed any test it is important to perform one, following the procedure shown. First of all, we have to make the distinction between System Level Test and Component Level Test. In **Figure 1** we can see a classification that illustrates this difference.

There is mainly one model for component level and another for system level, although there are others that we can apply. Although these models cannot replicate the full spectrum of all possible ESD events, they are successful in reproducing over 99% of all ESD failures [28].

A worker accumulates 500 - 2500 V in a normal working day. These values are higher than the damage level for the devices but lower than the detection threshold. The interaction of the operator that is not properly grounded with the devices produces the most common damages. These effects are simulated with the HBM.

The simulation circuit is shown in **Figure 2**. The power supply is a high voltage source that charges the capacitor, which accumulates the equivalent charge caught up by a human body. The switch transfers this charge to the device under test (DUT). By default, all devices must be considered as HBM sensitive. The standard that explains this model is ANSI/ESDA/JEDEC JS-001 Human Body Model Testing of Integrated Circuits [29].

Table 1 shows classification for defining the component sensitivity to the HBM. For more information about how to perform a sensitivity test based on HBM, see [30].

IEC 61000-4-2 [31] is used in a number of corporations to implement the DIRECTIVE 2006/42/EC, which does not specify any particular standard. The model used, shown in **Figure 3**, is similar to the HBM one.

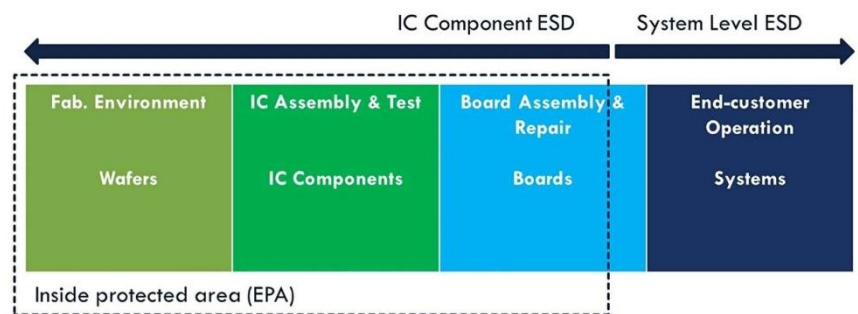

Figure 1. Classification of ESD-sensitive products [27].

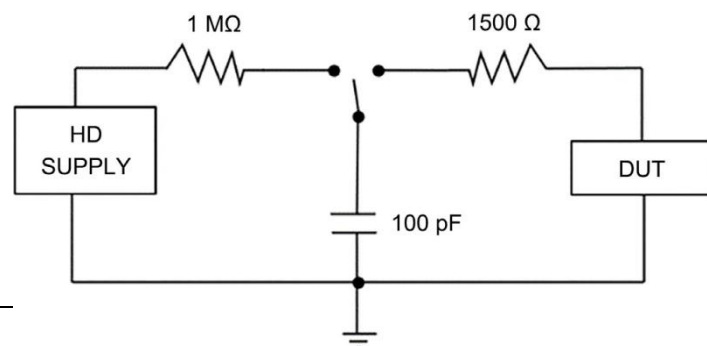

Figure 2. Simulation circuit for HBM.

Table 1. ESD classification for HBM.

Class	Voltage Range (V)
0	<250
1A	250 to <500
1B	500 to <1000
1C	1000 to <2000
2	2000 to <4000
3A	4000to <8000
3B	≥8000

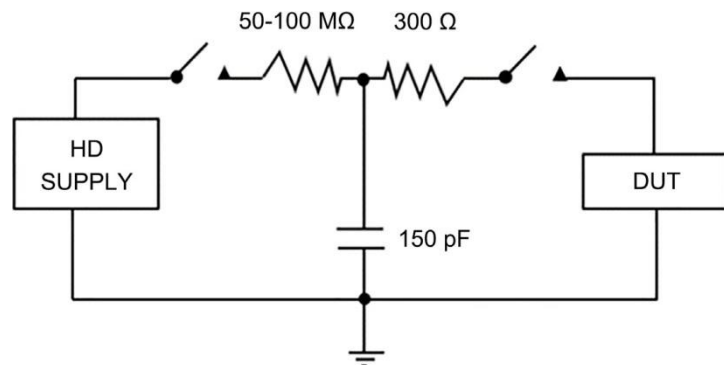

Figure 3. Simulation circuit for HBM.

The aim is to verify systems that are able to resist real ESD conditions, which is when discharges are produced by people in an uncontrolled environment, where it is assumed that the consumer does not have to take any special security measure to handle the product. Therefore, these tests are much stricter and de-structive [32] [33].

The stress must be applied to the areas that could make contact with the user. The results will vary according to the ground connection of the device and if it is switched on or off at the moment of the test. The tests are usually performed with the equipment switched on, although it could change depending on the concrete product and the situation in which this product is going to be handled. If they are performed with the system turned on, it is necessary to isolate any auxiliary device in order to protect them against discharges or disconnect them during the test and connect them after de-stress, just to make the verification.

There are two different methodologies for the test: stress by direct contact (applicable to conductive surfaces) and stress by air (applicable to insulating surfaces). The best option is to perform contact discharges first and then air discharges. The corresponding voltages to the different levels are going to be gradually applied following the classification shown in Table 2.

The test can start at level 1 or at a higher level if the equipment has security measures against ESD or a pre-determined sensitivity. In any case, in each stage five positive pulses and five negative pulses are applied (the order is irrelevant).

Table 2. ESD classification for HBM.

Test Voltage Discharge

Level	Contact (kV)	Air (kV)
1	2	2
2	4	4
3	6	8
4	8	15

If the device works correctly after the test, it passes to the next level until it fails, determining its sensitivity. IEC 61000-4-2 standard states that systems must pass Level 4, which corresponds to 8 kV stress per contact and 15 kV per air, but in some cases, it is enough with Level 3.

In addition to IEC 61000-4-2 there are other standards used for System Model Tests. One is the military standard MIL-STD-461G [34], in particular, CS118 Requirement, which is applicable to electrical, electronic, and electromechanical subsystems and equipment that have a man-machine interface. The procedure is similar to IEC 61000-4-2, and it uses the same methods to apply the discharge. Discharge levels are equal to the contact levels in IEC model but adding one more level (15 kV) just for air discharge.

HBM and IEC-61000-4-2 pursue similar objectives, and the differences between both standards have been the subject of numerous studies. Most relevant factors are the peak values and rise times of the discharge current, which are shown in **Table 3**.

Another important difference is the rise time. For HBM, the rise time is about 30 ns, while for IEC, the rise time is around 1 ns. This difference is critical to the effectiveness of on-chip protection structures, which usually depend on the rise time of the first pulse to turn on.

It is important to know what the threshold value for these protection structures is in order to avoid the destruction of the device before its protection circuits are even activated. It would also be necessary to define a set of waveforms that a component or a system may be exposed to during an ESD event in order to fully evaluate how the device will behave and design countermeasures at the board level to prevent failure [36].

An interesting aspect is that component level tests are destructive. That is because we perform the test until the device stops working correctly. The process is repeated with more samples of the same component to ensure that the maximum level is the same and determine the sensitivity. System level tests do not have to be destructive. The system can pass them with no damage at

all if they are properly designed.

4. A Case Study. Static Charge Control Plan for CTA-LST

CTA is a large scale research infrastructure consisting in an array of Cherenkov

Table 3. Peak current in a discharge (HBM vs. IEC) [35].

Test Voltage Discharge

Level	Contact (kV)	Air (kV)
1	2	2
2	4	4
3	6	8
4	8	15

Telescopes [37] [38]. The largest telescopes of these observatories, called Large Scale Telescopes (LST), are high precision instruments with advanced photo- multipliers able to detect the faint sub-nanosecond blue light pulses produced by Cherenkov Radiation. They are sensitive instruments installed in a harsh environment with difficult access, the Roque Observatory located in La Palma island. Detailed studies of soil resistivity revealed that the resistivity values ranged between 0.5 kΩ·m and 12 kΩ·m [39]. This posed severe difficulties in the design of the earthing system [40]. In addition, verification protocols were developed to verify the lightning protection system which was integrated in the own telescope structure [41].

The CTA-LST Static Charge Control Plan was developed following the guidelines described in Sections 2 and 3.

ESD Control in LST Sites and Laboratories

On the one hand, LST sites have been reviewed to identify any possible place for static charge accumulation in the LST structure, containers, fencing and access tower. In addition, ground resistances have been checked following the guidelines indicated in the technical report [42].

On the other hand, we have monitored the static charge in human body in LST site and laboratories in the worst conditions of relative humidity and temperature. For that purpose, we have used Electrostatic Voltmeter TREK MODEL 542A-2 [43] and the specific software. This voltmeter provides accurate non-contacting measurements of the electrostatic surface voltage that we can assume is independent of distance in a determined range between 30 and 60 mm. It has a capacitive probe to measure the static charge in surfaces and an adapter that we must grab, and it shows the static charge accumulated in human body.

Figure 4 shows the comparison between the measurements taken in 2019 and 2020, both in

Commissioning Container, in LST site. Red, orange and yellow lines correspond to three different measurements taken in 2019 and green, blue and purple ones are three measurements taken in 2020. These measurements were performed on an operator holding the voltmeter during a short walk she did along the commissioning container, together with an action of sitting and standing in one of the chairs with wheels for desk operation located in the container. The operator was not requested to wear any special footwear or clothing

Figure 4. Comparison between monitoring charge in human body measurements in May 2019 and August 2020.

since the tests were intended to be done in a worst-case scenario of a usual working day.

In 2019 campaign we can see that voltage rise to 18 kV. This was extremely dangerous even if we just work with complete systems as users, because even the most protected ones are tested with 15 kV. With voltages above 18 kV we cannot be sure of the correct maintenance of our systems. After this campaign, we warned of this problem and recommended to change the floor installation and replace the insulating floor for a conductive one. These renovations were made, and we performed another measurement campaign in August 2020. As we can see, the values decrease notably, reaching a maximum voltage of 2 kV. That value meets the requirements specified in the control plan. For design laboratories, we have also monitored the accumulation of static charge in human body and established the corresponding EPA where it was necessary.

ESD Control in Products

The Product Breakdown Structure of LST was developed during the design phase, including both custom made and commercial off-the-shelf components. It was necessary to determine which boards and devices have a greater necessity of an ESD test. The criteria we followed to determine which ones were more critical were the ones with CMOS technology and the density of pins present in the board. The devices whose pins are close each other, have more probability to feel a discharge.

To control in LST products, two types of tests were used. The first one, shown in **Figure 5**, is the ESD robustness made in INTA Laboratories following the standard MIL-STD-461G, explained before. It was performed by applying discharges in the main critical points of the board under test using an ESD simulator gun. Those application points were selected based on the probability of receiving a discharge either by direct contact by an operator or through tools or

Figure 5. ESD Robustness test following MIL-STD-461G.

other components that could acquire charge. The maximum voltage applied and passed in this case is 8 kV per contact and 15 kV per air (Level 4).

The second test was a precompliance one, shown in **Figure 6**. It was developed to bring some results for the robustness of the equipment before performing an official and certified test. Using the electrostatic voltmeter and its software we have monitored the static charge accumulated in the surface of the equipment while working in different situations, checking that the static charge accumulated is practically zero, thus considering that the equipment is suitable to pass an official test.

Discussion and Highlights

Common industrial standards provided valuable clues on how to develop a suitable static charge control plan for the CTA-LST project, but it was necessary to do a large amount of non-harmonized work to satisfy the specific needs of this installation. Research infrastructures comprise standalone prototyping laboratories, apart from the own installation site. The audits to prototyping laboratories made by experts on electromagnetic compatibility facilitated the awareness on the risks of ESD and gave the engineers valuable advice to suitably protect their products.

One of the major and not well understood issues with ESD damage is that this kind of stress not always produces an effect that can clearly be detected. It might happen that a device exposed to an ESD still continues working, but with a reduced lifetime and/or a degraded performance. When this device is integrated in a complex subsystem formed by a large number of other devices working with it, detecting the origin of a failure becomes cumbersome and sometimes impossible.

Among most common ESD sources we must cite charged insulators, human operators and isolated and charged conductive parts. Effective ESD control in both prototype manufacturing and instrument operation environments requires

Figure 6. Monitoring charge accumulated in surface using Trek Voltmeter 542A-2.

that real ESD threats are well assessed. The installation of the facility in a harsh environment requires special procedures. The CTA observatory site is located in an environment where very low humidity days (RH below 10%) are common. The large electrical resistivity of the soil further complicates the situation, since high quality earthing becomes difficult. In this case, regular checks must be included in the maintenance plan to monitor the accumulation of the static charge in human operators. The use of an electrostatic voltmeter to monitor in real time the

charge accumulation in the human body is a powerful tool to predict and assess the ESD risks. In addition, special protocols based on the guidelines described in Section 2.2 should be adopted.

5. Conclusions

The goal of this work is to offer relevant and practical guidance on the procedures to be followed when creating a static charge control strategy for substantial research infrastructure. It draws attention to the need to address one of the most frequently overlooked issues in electronics, one that impacts both workplaces—whether they are laboratories for the design of sensitive components or not—and the tools utilized

A static charge control plan for a research infrastructure must identify the persons in charge and their roles, the actions to take, and the deliverables to provide. The actions to cover must ensure that static charge control is guaranteed not only in the own installation but also in the production laboratories. It must also guarantee that the critical parts are identified within the product breakdown structure, and that specific tests on those parts are made to assess that the part will be able to withstand any reasonably foreseeable exposure to a static discharge.

In order to clarify how the static charge control plan is implemented, the application to a large-scale scientific instrument consisting of an array of telescopes hosting sensitive equipment and located in a harsh environment is discussed. The plan developed following the ideas presented here helped to prevent failures on static discharges that would have led to costly damages.

Conflicts of Interest

The authors declare no conflicts of interest regarding the publication of this paper.

References

- [1] N. ESD Association (2010) Fundamentals of Electrostatic Discharge—Part 1: An Introduction to ESD.
<https://www.esda.org/esd-overview/esd-fundamentals/part-1-an-introduction-to-esd/>
- [2] Diep, T. and Cline, R. (2014) Application Report Electrostatic Discharge (ESD).
<https://www.ti.com>
- [3] EMIT-Videos. <http://emit.descoindustries.com/Video.aspx>
- [4] N. ESD Association (2011) ANSI/ESD—S20.20—ESD Association Standard for the Development of Electrostatic Discharge Control Program for Protection of Electrical and Electronic Parts, Assemblies and Equipment (Excluding Electrically Initiated Explosive Devices).
<https://www.esda.org>
- [5] N. ESD Association (2016) ESD Association Technical Report—Handbook for the Development of an Electrostatic Discharge Control Program for the Protection of Electronic

- Parts, Assemblies and Equipment. <https://www.esda.org/standards/factory/esd-control-program/view/1719>
- [6] N. ESD Association (2010) Fundamentals of Electrostatic Discharge—Part 2: Principles of ESD Control. <https://www.esda.org/esd-overview/esd-fundamentals/part-2-principles-of-esd-control/>
- [7] N. ESD Association (2010) Fundamentals of Electrostatic Discharge—Part 3: Basic ESD Control Procedures and Materials. <https://www.esda.org/esd-overview/esd-fundamentals/part-3-basic-esd-control-procedures-and-materials/>
- [8] S. International Electrotechnical Commission. Geneva (2016) IEC 61340-5-1: Electrostatics—Part 5.1: Protection of Electronics Devices from Electrostatic Phenomena. General Requirements. <https://webstore.iec.ch/publication/24958>
- [9] E. Association (2005) ESDA: ANSI/ESD S6.1-2005 for the Protection of Electrostatic Discharge Susceptible Items Grounding. <https://www.esda.org/standards>
- [10] ESD Awareness Booklet. <https://www.ESDA.org/standards>
- [11] D.S. Items (2006) ANSI/ESD-S1.1-Wrist Straps. <https://www.esda.org/standards/factory/wrist-straps>
- [12] N. ESD Association (2006) ANSI/ESD S4.1—ESD Association Standard for the Protection of Electrostatic Discharge Susceptible Items-Work Surfaces-Resistance Measurements.
- [13] N. ESD Association (2006) ANSI/ESD S4.2—ESD Association Standard for the Protection of Electrostatic Discharge Susceptible Items-Work Surfaces-Charge Dissipation Characteristics.
- [14] E. Association (2015) ANSI/ESD S7.1—ESD Association Standard for the Protection

C. Oliver *et al.*

- of Electrostatic Discharge Susceptible Items—Floor Materials—Characterization of Materials.
- [15] Staticworx Grounded Solutions (2020) Selecting a Static-Control Floor Matching Products and Environments through Evidence-Based Design Choosing the Right ESD Floor. https://kb.staticworx.com/wp-content/uploads/2018/03/Choosing_an_ESD_Floor_bro.pdf
- [16] N. ESD Association (2015) ANSI/ESD STM97.1—ESD Association Standard Test Method for the Protection of Electrostatic Discharge Susceptible Items—Floor Materials and Footwear—Resistance in Combination with a Person. <https://www.esda.org/standards/esda-documents/view/1598>
- [17] N. ESD Association (2016) ANSI/ESD STM97.2—ESD Association Standard Test Method for the Protection of Electrostatic Discharge Susceptible Items—Floor Materials and Footwear—Voltage Measurements in Combination with a Person. <http://www.esda.org>
- [18] (2003) ANSI/ESD-SP9.1—Footwear-Foot Grounders Resistive Characterization (Not to Include Static Control Shoes)®. <http://img55.afzhan.com/1/20130913/635146610903827137876.pdf>

- [19] Recommendations for the Use and Test of ESD Protective Garments in Electronics Industry.
<https://www.astena.ru>
- [20] N. ESD Association (2013) ANSI/ESD STM2.1—ESD Association Standard Test Method for the Protection of Electrostatic Discharge Susceptible Items—Garments. Characterization. <https://www.esda.org/standards/esda-documents/view/1583>
- [21] E. Association (2005) ESD Association Standard Practice for Protection of Electrostatic Discharge Susceptible Items-in-Use Resistance Testing of Gloves and Finger Cots. <https://www.esda.org/standards/factory/gloves-and-finger-cots>
- [22] (1999) JEDEC Standard Requirements for Handling Electrostatic-Discharge-Sensitive (ESDS) Devices JESD625-A Electronic Industries Alliance JEDEC Solid State Technology Association. <https://www.jedec.org>
- [23] N. ESD Association (2015) ANSI/ESD STM3.1—ESD Association Standard Test Method for the Protection of Electrostatic Discharge Susceptible Items—Ionization. <https://www.esda.org/standards/esda-documents>
- [24] (2003) ANSI/ESD S541: For the Protection of Electrostatic Discharge Susceptible Items Packaging Materials for ESD Sensitive Items. <https://www.esda.org/standards/factory/packaging>
- [25] E. Association (2008) ANSI/ESD S8.1—For the Protection of Electrostatic Discharge Susceptible Items-Symbols-ESD Awareness. <http://img51.afzhan.com/1/20130910/635144050647161265449.pdf>
- [26] L. Hood and N. ESD Association (2010) TR53-01-06—ESD Association Technical Report for the Protection of Electrostatic Discharge Susceptible Items—Compliance Verification of ESD Protective Equipment and Materials.
- [27] Dekker, M. (2011) ESD Models and Protection Methods.
- [28] N. ESD Association (2010) Fundamentals of Electrostatic Discharge—Part 5: Device Sensitivity and Testing. <https://www.esda.org/esd-overview/esd-fundamentals/part-5-device-sensitivity-and-testing/>
- [29] ESDA and JEDEC (2012) ANSI/ESDA/JEDEC JS-001 Human Body Model Testing of Integrated Circuits.

C. Oliver *et al.*

<http://www.jedec.org/sites/default/files/JTR001-01-12Final.pdf>

- [30] Oliver, C. (2018) Sensitivity Test Based on HBM. Video in YouTube Channel. https://www.youtube.com/watch?v=L8jcLS_Kk4g
- [31] IEC61000-4-2: Testing and Measurement Techniques—Electrostatic Discharge Immunity

- Test. <https://webstore.iec.ch/publication/4189>
- [32] Smedes, T. (2009) ESD Testing of Devices, ICs and Systems. *Microelectronics Re-liability*, **49**, 941-945. <https://doi.org/10.1016/j.microrel.2009.07.013>
- [33] Labs, S. (2018) Recommended ESD Test Bench Figure 1. IEC 61000-4-2 Test Bench 3.2. Simulation Circuit Figure 2. Simulation Circuit of IEC 61000-4-2. <https://www.silabs.com/documents/public/application-notes/AN895.pdf>
- [34] (2007) MIL-STD-461G Department of Defense Interface Standard Requirements for the Control of Electromagnetic Interference Characteristics of Subsystems and Equip-ment. [https://www.trentonsystems.com/hubfs/MIL-STD-461G%20\(1\).pdf?hsCtaTracking=1301191e-85c1-466e-8089-2f081b2c1440%7C3c0dcd69-d523-4114-98e9-4170ed629674](https://www.trentonsystems.com/hubfs/MIL-STD-461G%20(1).pdf?hsCtaTracking=1301191e-85c1-466e-8089-2f081b2c1440%7C3c0dcd69-d523-4114-98e9-4170ed629674)
- [35] IEC (2013) Human Body Model (HBM) vs. IEC IEC61000-4-2. *Journal of Chemical Information and Modeling*, **53**, 1688-1699. <http://www.protekdevices.com/xyz/documents/kb/tech/ta1036.pdf>
- [36] Carn, B. (2010) White Paper 3 System Level ESD Part I: Common Misconceptions and Recommended Basic Approaches Industry Council on ESD Target Levels. <https://www.esdindustrycouncil.org/ic/docs/Industry%20Council%20White%20Paper%203%20PI%20Rev1%20Dec%202010.pdf>
- [37] Acharya, B.S., *et al.* (2013) Introducing the CTA Concept. *Astroparticle Physics*, **43**, 3-18. <https://doi.org/10.1016/j.astropartphys.2013.01.007>
- [38] Actis, M., *et al.* (2011) Design Concepts for the Cherenkov Telescope Array CTA: An Advanced Facility for Ground-Based High-Energy Gamma-Ray Astronomy. *Experimental Astronomy*, **32**, 193-316. <https://doi.org/10.1007/s10686-011-9247-0>
- [39] Ronda, S., Martinez, O., Oliver, C., Marquez, P. and Miranda, J.M. (2020) Finite Element Analysis and Experimental Characterization of Soil Electrical Resistivity at El Roque de los Muchachos Observatory. *Journal of Electromagnetic Analysis and Applications*, **7**, 89-102.
- [40] Ronda, S., Oliver, C., Martinez, O., Marquez, P. and Miranda, J.M. (2020) Applying Electromagnetic Field Analysis to Minimize the Earth Resistance on High Resistivity Soils. *Progress in Electromagnetics Research M*, **96**, 157-167. <https://doi.org/10.2528/PIERM20072303>
- [41] Martinez, O., Ronda, S., Oliver, C., Marquez, P. and Miranda, J. (2019) Verification Protocols for the Lightning Protection of a Large Scale Scientific Instrument in Harsh Environments: A Case Study. *Journal of Power and Energy Engineering*, **9**, 12-28.
- [42] Iglesias, A., Miranda, J.M. and Oliver, C. (2018) LST_RAMs181106 Resistivity Ground Resistance. CTA Internal Report Available on Request (miranda@ucm.es).
- [43] Trek Inc. (2013) Trek Model 542A Non-Contacting Electrostatic Voltmeter for EOS/ESD Key Specifications.