

Vehicle-To-Grid Technology in a Micro-grid Using DC Fast Charging Architecture

N.Manoj Kumar
Assistant Professor

Dept.of Electrical and Electronics Engineering,
Anantha Lakshmi Institute of Technology and Sciences,
Ananthapuramu.

C.Ranganath
Assistant Professor

Dept.of Electrical and Electronics Engineering,
Anantha Lakshmi Institute of Technology and Sciences,
Ananthapuramu.

Abstract— Electric Vehicle (EV) batteries can be utilized as potential energy storage devices in micro-grids. They can help in micro-grid energy management by storing energy when there is surplus (Grid-To-Vehicle, G2V) and supplying energy back to the grid (Vehicle-To-Grid, V2G) when there is demand for it. Proper infrastructure and control systems have to be developed in order to realize this concept. Architecture for implementing a V2G-G2V system in a micro-grid using level-3 fast charging of EVs is presented in this paper. A micro-grid test system is modeled which has a dc fast charging station for interfacing the EVs. Simulation studies are carried out to demonstrate V2G-G2V power transfer. Test results show active power regulation in the micro-grid by EV batteries through G2V-V2G modes of operation. The charging station design ensures minimal harmonic distortion of grid injected current and the controller gives good dynamic performance in terms of dc bus voltage stability.

I. INTRODUCTION

Energy storage systems are important components of a micro-grid as they enable the integration of intermittent renewable energy sources. Electric vehicle (EV) batteries can be utilized as effective storage devices in micro-grids when they are plugged-in for charging. Most personal transportation vehicles sit parked for about 22 hours each day, during which time they represent an idle asset. EVs could potentially help in micro-grid energy management by storing energy when there is surplus (Grid-To-Vehicle, G2V) and feeding this energy back to the grid when there is demand for it (Vehicle-To-Grid). V2G applied to the general power grid faces some challenges such as; it is complicated to control, needs large amount of EVs and is hard to realize in short term. In this scenario, it is easy to implement V2G system in a micro-grid.

The Society of Automotive Engineers defines three levels of charging for EVs. Level 1 charging uses a plug to connect to the vehicle's on-board charger and a standard household (120 V) outlet. This is the slowest form of charging and works for those who travel less than 60 kilometers a day and have all night to charge. Level 2 charging uses a dedicated Electric Vehicle Supply Equipment (EVSE) at home or at a public station to provide power at 220 V or 240 V and up to 30 A. The level 3 charging is also referred to as dc fast charging. DC fast charging stations provide charging power up to 90 kW at 200/450 V, reducing the charging time to 20-30 mins. DC fast charging is preferred for implementing a V2G architecture in micro-grid due to the quick power transfer that is required when EVs are

utilized for energy storage. Also the dc bus can be used for integrating renewable generation sources into the system.

In majority of the previous studies, V2G concept has been applied in the general power grid for services like peak shaving, valley filling, regulation and spinning reserves. The V2G development in a micro-grid facility to support power generation from intermittent renewable sources of energy is still at its infancy. Also, level 1 and level 2 ac charging is utilized for V2G technology in most of the works reported. These ac charging systems are limited by the power rating of the on-board charger. An additional issue is that the distribution grid has not been designed for bi-directional energy flow. In this scenario, there is a research need for developing technically viable charging station architectures to facilitate V2G technology in micro-grids. This work proposes a dc quick charging station infrastructure with V2G capability in a micro-grid facility. The dc bus used to interface EVs is also used for integrating a solar photo-voltaic (PV) array into the micro-grid. The proposed architecture allows high power bi-directional charging for EVs through off-board chargers. Effectiveness of the proposed model is evaluated based on MATLAB/Simulink simulations for both V2G and G2V modes of operation.

II. DC FAST CHARGING STATION CONFIGURATION FOR V2G

The configuration for dc fast charging station to implement V2G-G2V infrastructure in a micro-grid is shown in Fig. 1. EV batteries are connected to the dc bus through off-board chargers. A grid connected inverter connects the dc bus to the utility grid through an LCL filter and a step-up transformer. The important components of the charging station are described below.

A. Battery Charger Configuration

For dc fast charging, the chargers are located off-board and are enclosed in an EVSE. A bidirectional dc-dc converter forms the basic building block of an off-board charger with V2G capability. It forms the interface between EV battery system and the dc distribution grid. The converter configuration is shown in Fig. 2. It consists of two IGBT/MOSFET switches that are always operated by complimentary control signals.

1) *Buck mode of operation (charging mode)*: When the upper switch (S_{buck}) is operating, the converter acts as a buck converter stepping down the input voltage (V) to battery charging voltage (V_{batt}). During the on state, current flows through the switch and inductor to the battery. This is the charging operation, where the power flow is from the grid to

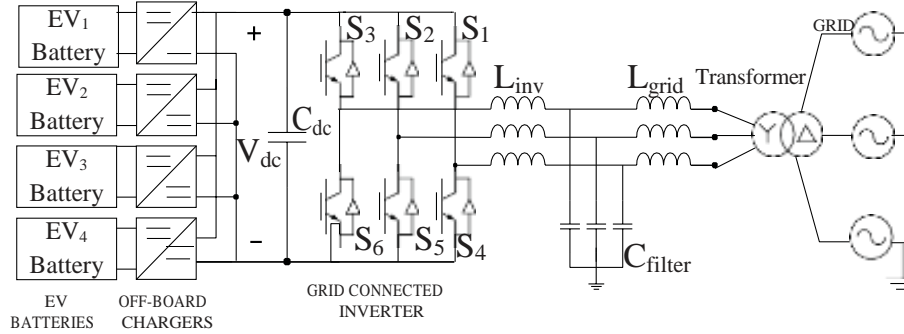

Fig. 1. EV charging station for fast dc charging

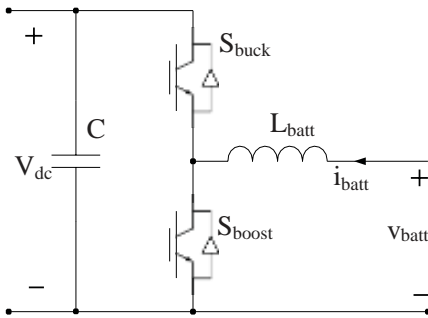

Fig. 2. Battery charger configuration

vehicle (G2V). When the switch is off, the current takes its return path through the inductor and diode of lower switch and completes the circuit. If D is the duty ratio of the upper switch, the battery voltage is given by:

$$V_{batt} = V_{dc} * D \quad (1)$$

2) *Boost mode of operation (discharging mode):* When the lower switch (S_{boost}) is operating, the converter acts as a boost converter stepping up the battery voltage (V_{batt}) to the dc bus voltage (V_{dc}). When the switch is in on state, current continues to flow through the inductor and completes its circuit through the anti-parallel diode of the upper switch, and the capacitor. The net power flow in this case is from the vehicle to the grid (V2G) and the battery operates in the discharge mode. If the capacitor is large enough to provide a constant dc voltage, the output voltage during boost mode of operation is given by:

$$V_{dc} = \frac{V_{batt}}{1 - D'} \quad (2)$$

where D' is the duty cycle of the lower switch.

B. Grid Connected Inverter and LCL Filter

The grid connected inverter (GCI) converts the dc bus voltage into a three phase ac voltage and also allows the reverse flow of current through the anti-parallel diodes of the switches in each leg (Fig. 1). An LCL filter is connected at the output terminals of the inverter for harmonic reduction and obtaining a pure sinusoidal voltage and current. The design procedure for determining the LCL filter parameters for this work is adapted from equation 2.

III. CONTROL SYSTEM

A. Off-Board Charger Control

A constant current control strategy using PI controllers is implemented for charge/discharge control of the battery charger circuit and is shown in Fig.3. The controller first compares the reference battery current with zero, in-order to determine the polarity of the current signal, to decide between charging and discharging modes of operations. Once the mode is selected, the reference current is compared with the measured current and the error is passed through a PI controller to generate the switching pulses for S_{buck}/S_{boost} . S_{boost} will be turned off throughout the charging process and S_{buck} will be turned off throughout the discharging process.

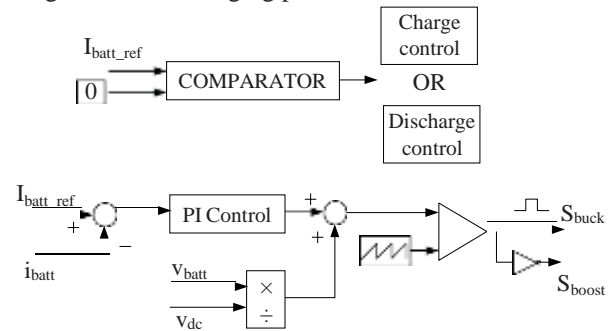

Fig. 3. Constant current control strategy for battery charger

B. Inverter Control

A cascade control in synchronous reference frame is proposed for the inverter controller. The conventional standard vector control using 4 PI controllers in a nested loop is shown in Fig. 4. The control structure consists of two outer voltage control loops and two inner current control loops. The d-axis outer loop controls the dc bus voltage and inner loop controls the active ac current. Similarly, the q-axis outer loop regulates the ac voltage magnitude by adjusting the reactive current, which is controlled by the q-axis inner current loop. Also, dq decoupling terms ωL and feed-forward voltage signals are added to improve the performance during transients.

IV. MICRO-GRID TEST SYSTEM CONFIGURATION

The micro-grid test system configuration with the dc fast charging station is shown in Fig. 5. A 100 kW wind turbine (WT) and a 50 kW solar PV array serve as the generation sources

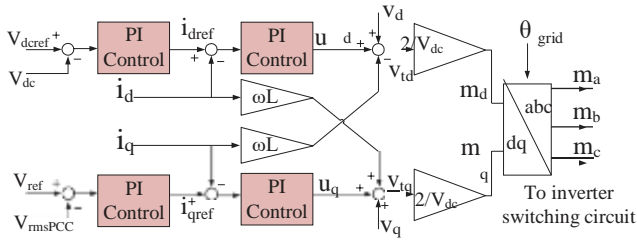

Fig. 4. Inverter control system

in the system. The EV battery storage system consists of 4 EV batteries connected to a 1.5 kV dc bus of the charging station through off-board chargers. The solar PV is also connected to this dc bus through a boost converter which has a maximum power point tracking (MPPT) controller. The utility grid consists of a 25 kV distribution feeder and a 120 kV equivalent transmission system. The wind turbine driven doubly-fed induction generator is connected to the micro-grid at the point of common coupling (PCC). Transformers are used to step up the voltages and connect the respective ac systems to the utility grid.

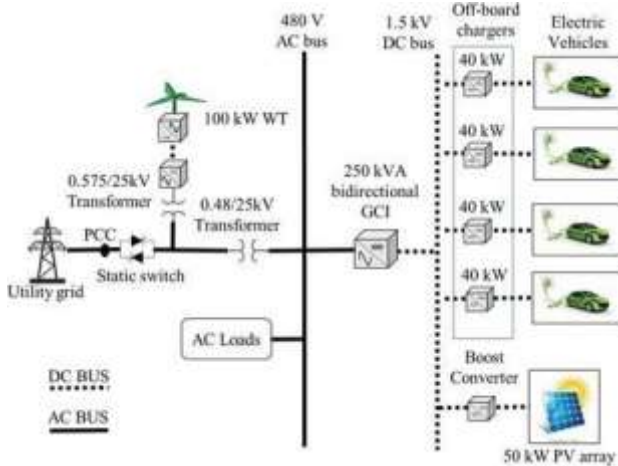

Fig. 5. Proposed microgrid test system configuration

V. SIMULATION RESULTS

The charging station design procedure is adapted from [1] and the obtained parameter values are given in Appendix. The wind turbine is operated at rated speed giving an output maximum power of 100 kW. The solar PV is operated at standard test conditions (1000W/m² irradiance and 25°C temperature) giving the maximum power output of 50 kW. A 150 kW resistive load is connected to the 480 V ac bus. The reactive current reference to GCI is set to zero for unity pf operation. The initial state of charge (SOC) of the EV batteries is set at 50%. Once the steady state conditions are reached, batteries of EV₁ and EV₂ (Fig. 1) are operated to perform the V2G-G2V power transfer. The current set-points given to the battery charging circuits of EV₁ and EV₂ batteries are shown in Table I and the results are shown in the subsequent figures.

The battery parameters when EV₁ is operating in V2G mode and EV₂ operating in G2V mode are shown in Figs. 6 and 7, respectively.

TABLE I. CURRENT SET-POINTS TO EV BATTERIES

Time range (s)	0 to 1	1 to 4	4 to 6
Current set-point to EV ₁ battery (A)	0	+80	0
Current set-point to EV ₂ batter y(A)	0	0	-40

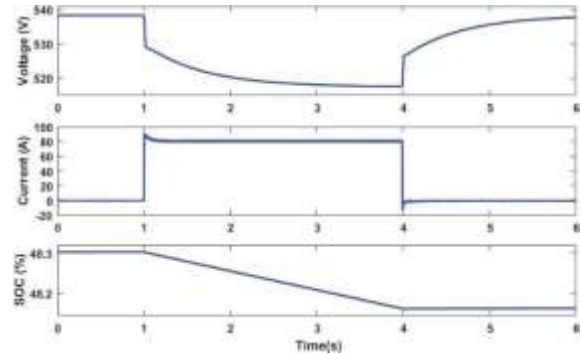

Fig. 6. Voltage, current, and SOC of EV₁ battery during V2G operation

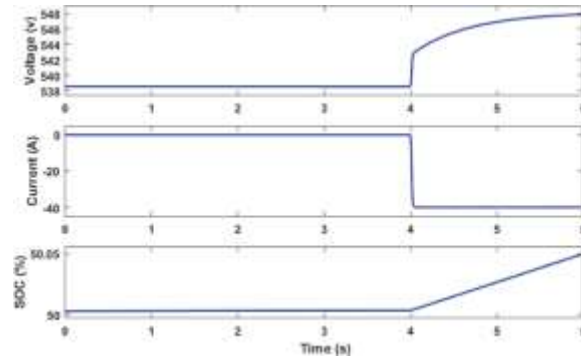

Fig. 7. Voltage, current, and SOC of EV₂ battery during G2V operation

The active power contribution from various components of the system is shown in Fig. 8. The grid power changes to accommodate the power transferred by the EVs. The negative polarity of the grid power from 1s to 4s shows that the power is being fed to the grid from the vehicle. The change in polarity of grid power at 4s shows that the power is supplied by the grid for charging the vehicle battery. This demonstrates the V2G-G2V operation. Also, the net power at PCC is zero showing an optimal power balance in the system.

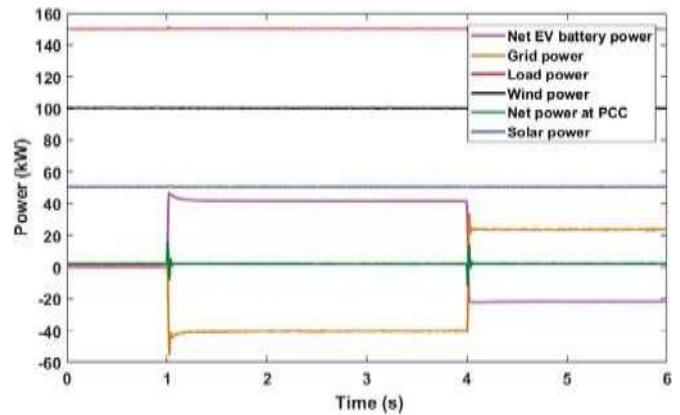

Fig. 8. Active power profile of various components in the system

The dc bus voltage is regulated at 1500 V by the outer voltage control loop of the inverter controller and is shown in Fig. 9. This in turn is achieved by the inner current control loop tracking the changed d-axis reference current as shown in Fig. 10.

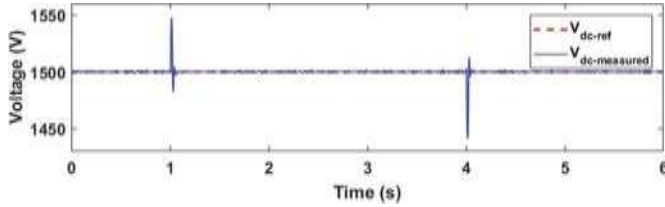

Fig. 9. Variation in dc bus voltage

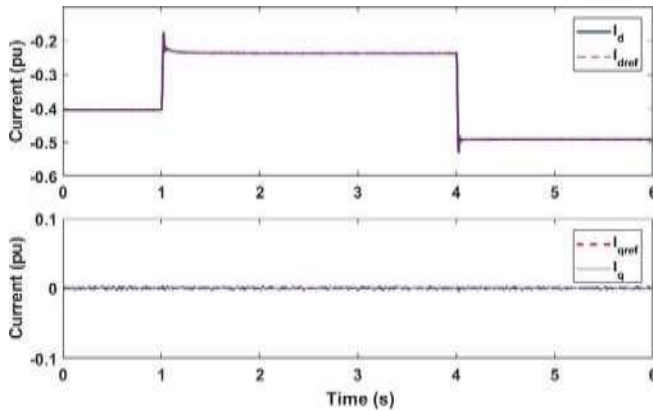

Fig. 10. Reference current tracking by inverter controller

The grid voltage and current at PCC are shown in Fig. 11. Voltage and current are in phase during G2V operation and 180° out of phase during V2G operation showing the reverse power flow.

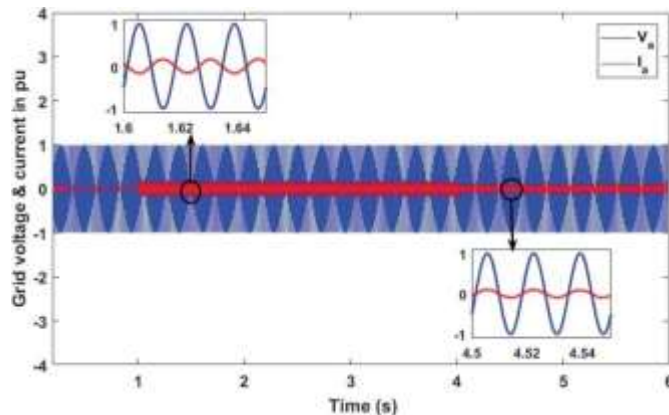

Fig. 11. Grid voltage and grid injected current during V2G-G2V operation

Total harmonic distortion (THD) analysis is done on the grid injected current and the result is shown in Fig. 12. According to IEEE Std. 1547, harmonic current distortions on power systems 69 kV and below are limited to 5% THD. The THD of grid-injected current is obtained as 2.31 % and is achieved by the judicious design of LCL filter.

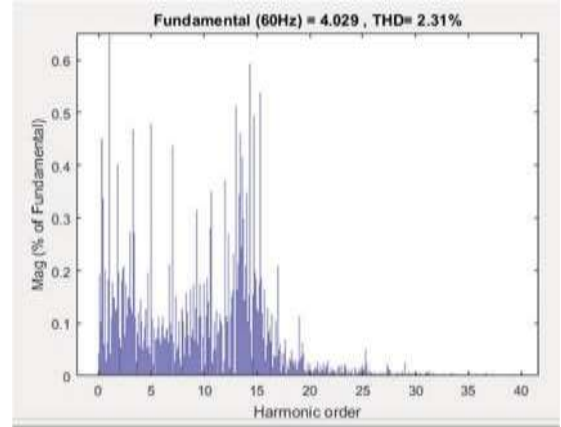

Fig. 12. Harmonic spectrum and THD of grid-injected current

VI. CONCLUSIONS

Modeling and design of a V2G system in a micro-grid using dc fast charging architecture is presented in this paper. A dc fast charging station with off-board chargers and a grid connected inverter is designed to interface EVs to the micro-grid. The control system designed for this power electronic interface allows bi-directional power transfer between EVs and the grid. The simulation results show a smooth power transfer between the EVs and the grid, and the quality of grid injected current from the EVs adheres to the relevant standards. The designed controller gives good dynamic performance in terms of dc bus voltage stability and in tracking the changed active power reference. Active power regulation aspects of the micro-grid are considered in this work, and the proposed V2G system can be utilized for several other services like reactive power control and frequency regulation. Design of a supervisory controller which gives command signals to the individual EV charger controllers is suggested for future research.

REFERENCES

- [1] C. Shumei, L. Xiaofei, T. Dewen, Z. Qianfan, and S. Liwei, "The construction and simulation of V2G system in micro-grid," in *Proceedings of the International Conference on Electrical Machines and Systems, ICEMS 2011*, 2011, pp. 1–4.
- [2] S. Han, S. Han, and K. Sezaki, "Development of an optimal vehicle-to-grid aggregator for frequency regulation," *IEEE Trans. Smart Grid*, vol. 1, no. 1, pp. 65–72, 2010.
- [3] M. C. Kisacikoglu, M. Kesler, and L. M. Tolbert, "Single-phase on-board bidirectional PEV charger for V2G reactive power operation," *IEEE Trans. Smart Grid*, vol. 6, no. 2, pp. 767–775, 2015.
- [4] A. Arancibia and K. Strunz, "Modeling of an electric vehicle charging station for fast DC charging," in *Proceedings of the IEEE International Electric Vehicle Conference (IEVC)*, 2012, pp. 1–6.
- [5] K. M. Tan, V. K. Ramachandaramurthy, and J. Y. Yong, "Bidirectional battery charger for electric vehicle," in *2014 IEEE Innovative Smart Grid Technologies - Asia, ISGT ASIA 2014*, 2014, pp. 406–411.

APPENDIX

CHARGING STATION PARAMETERS

Parameter	Value	Parameter	Value
Rated capacity	250 kVA	EV rated power	40 kW
V_{batt}	500 V	Battery capacity	48 Ah
C_{dc}	850 μF	C_{filter}	133 μF
L_{inv}	0.25 mH	L_{grid}	0.25 mH