

# Hiding Security System For Alone Women By Using GSM & GPS

K.Tirupathaiah<sup>1</sup>, P.Vyshnavi<sup>2</sup>, M.Bhavani<sup>3</sup>, S.Ajay kumar<sup>4</sup>, S.Mahesh kumar<sup>5</sup>

<sup>1</sup>Assistant Professor, ECE, SMCE, Thummalapalem, Andhra Pradesh, India.

<sup>1</sup> [tiru434@gmail.com](mailto:tiru434@gmail.com)

<sup>2,3,4,5</sup> Student, ECE, SMCE, Thummalapalem, Andhra Pradesh, India.

<sup>2</sup> [vyshnaviparuchuri476@gmail.com](mailto:vyshnaviparuchuri476@gmail.com)

<sup>3</sup> [marriboinabhavani@gmail.com](mailto:marriboinabhavani@gmail.com)

**Abstract** - The world is becoming unsafe for women in all aspects. The crime against women are increasing at a higher rate. The employed women are feeling unsafe due to increasing crimes. This paper proposes a quick responding mechanism that helps women during trouble. When someone is going to harass, she can just press the button and the location information is sent as an SMS alert to few pre-defined numbers in terms of latitude and longitude. The controller used is ATMEGA328P. It is interfaced with a push button, a GPS module, a GSM modem and a LCD Display (16×2). If the switch is pressed, the controller take the current location information from the GPS module and send those data to the predefined no. using a GSM modem. The program is developed in 'C' language. The purpose of this project is to feel safe the women's.

**Key Words:** Arduino, GPS, GSM, LCD Display

## 1.INTRODUCTION

Even in this modern era women are feeling insecure to step out of their house because of increasing crimes in our country like harassment, abuse, violence etc., The corporate and IT sector are currently in boom. Many women are working in corporate even in night shifts. There is a feeling of insecurity among the working women. The proposed device is more like a safety system in case of emergency. This device can be fitted in a jacket (similar to a blazer for women). It is an easy to carry device with more features and functions.

The emergency push button is held to one of the buttons of the jacket. The main purpose of this device is to intimate the parents and police about the current location of the women. A GPS system is used to trace the current position of the victim and a GSM modem is used to send the message to the pre-defined numbers. This model is also useful for small children's, elderly aged people also.[2]

## 2. GOAL AND OBJECTIVE

The main purpose of our project is to provide safety to the women's from the dangerous zone. In this project we are providing facility to secure the women's by providing this kit. As the women feels insecure at that time she can press the button .GPS will calculate the latitude and longitude co- ordinates of that area. The controller read this value and send those data to the pre-defined number which is already saved.

### 3.METHOD

#### Design Overview

The Block diagram of our proposed system is as shown below:

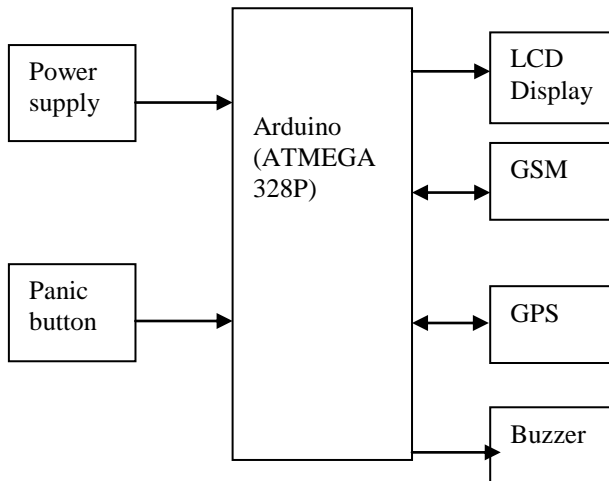

**Fig-1:** Block Diagram of Women Security System

This system consist of following component which are listed below.

- a. Arduino (ATMEGA 328P)
- b. LCD Display (16×2)
- c. GSM Module(SIM800A)
- d. GPS Module(SIM28ML)
- e. Power supply
- f. Panic button

#### 3.1 Arduino:

This development board provides small plate with the same powerful microcontroller like Arduino Uno. The Arduino Nano is small in size that uses ATMEGA328P Microcontroller. It operates on 5V DC supply. Remaining all component interface with this device. The RX and TX pin of this device is connected to the TX and RX of the GSM modem of SIM800 Module. D10 Pin is connected to the TX of The GPS module.D2 to D7 Pin is connected to the LCD Display.

#### 3.2 LCD Display (16×2):

This display contains two internal byte wise resistors, One for the commands (RS=0) and second for character to be displayed (RS=1). It also contains a user programmed RAM area (the character RAM) that can be programmed to generate any desired character that can form using a dot matrix. To distinguish between these two data areas. The display takes varying amounts of time to accomplish the functions. D4-D7 pin is connected to the D2-D5 Pin of Arduino. RS and EN Pin of display is connected to the D6, D7 Pin Respectively also by giving a proper supply and system ground LCD is ready to display the data. [3]

#### 3.3 GSM Module (SIM 800A):

The GSM module can accept any GSM network operator SIM card and act just like a mobile phone with its own unique phone number. GSM/GPRS modem is a class of wireless modem devices that are designed for communication of a computer with the GSM and GPRS network. It requires a SIM Card just like a mobile phones to activate communication with the network. Also they have an IMEI (International Mobile Equipment Identity). Similar to a mobile phones for their identification. The module can perform following operations. [4]

1. Receive, send or delete SMS messages in a SIM.
2. Read, add, search phonebook entries of the SIM.
3. Make, receive or reject a voice call.

The TX, RX, GND Pin of this module is connected to the respective pin of Arduino and is supplied by the 12volt, 2AMP Adaptor. [4]

#### 3.4 GPS Model:

It consists of six wires out of which three wires are used for connection. The TX pin of this module which is connected to the D10 pin of the microcontroller. Voltage supply is about 3.3V to 5V. When Push button is pressed, GPS starts receiving signals from 4 satellites out of the 24 satellites in the orbit.

Once if the connection is established the latitude and longitude values of the current location are obtained. The GPS acts as a transmitter. The 5V supply is given to the GPS from the controller. [4]

### 3.5 Power Supply:

To make the DC power supply of 5volt we used step down transformer, bridge circuit, filter circuit and finally fixed voltage regulator. In this system we used step down transformer in which primary voltage is greater than secondary voltage.in this system we used 9-0-9 step down transformer.so at the transformer output we got 9volt AC. Then we used bridge circuit whose job to perform to convert AC into pulsating DC. Then filter is used to remove the noisy pulses and convert pulsating DC into pure DC. Then IC7805

Regulator is used which provides fixed positive 5V DC Output. This voltage is required to work the Arduino.

### 3.6 Panic button:

When it is pressed then it will send GPS signal to the controller, then controller will send the GPS coordinates via GSM to the pre-defined numbers.

## 4. RESULT:

Fig 2. Shows the hardware setup of system and fig 3. Shows the tracking location when user pressed the key that shows the final result.



**Fig-2:** Hardware set up of system.

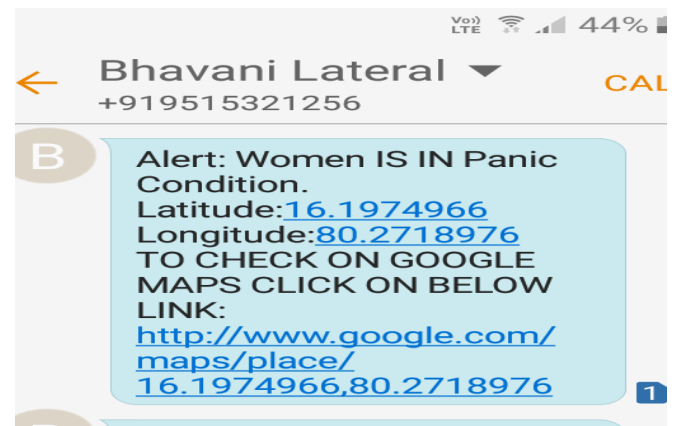

**Fig-3:** Tracking location

## 5. FUTURE SCOPE:

- 1) In future, system can be interface with the Camera for capturing image and recording live video also.
- 2) By using Nano sized materials, kit size can be reduced.
- 3) We use wireless GPS modem and wireless Panic button the carrying of the kit can be avoided.
- 4) More effective system can be designed by adding MOTION DETECTOR Technology

## 6.APPLICATIONS:

- 1) It will be used for safety of women's.
- 2) It will be used for child tracking during school time.
- 3) It will be used in vehicle tracking & safety system.
- 4) It will be used for safety of elderly aged people.

## **7.CONCLUSION:**

Our effort behind this project is to design and fabricate a gadget which is so compact in itself that provide advantage of personal security system the emergency response system which is helpful for women in the incidents of crime. It is low cost system which can store the data of the members in the particular locality and provide immediate alert in case of crime against women. This provides women security. Being safe and secure is the demand of the day. This system can overcome the fear that scares every woman in the country about her safety and security.

## **8.REFERENCES:**

[1]Premkumar.P, Cibi Chakkaravarthi.R, Keerthana. M, Ravivarma. R, Sharmila. “ONE TOUCH ALARM SYSTEM FOR WOMEN’S SAFETY USING GSM” International Journal of Science Technology & Management, 2015 March.

[2]Nishant Bhardwaj and Nitish Aggarwal Design and Development of “SURAKSHA”-A Women Safety Device International Journal of Information & Computation Technology, ISSN 0974-2239 Volume 4, Number 8 (2014), pp. 787-792

[3]B.Vijaylaxmi, Renuka.S,PoojaChennur, Sharangowda.Patil. “SELF DEFENSE SYSTEM FOR WOMEN SAFETY WITH LOCATION TRACKING AND SMS ALERTING THROUGH GSM NETWORK” International Journal Research in Engineering And Technology (IJARTET), 2015 May.

[4]Gowri Predeba B, Shyamala. N, Tamilselvi.E, Ramalakshmi.S, Selsialvina. “WOMEN SECURITY SYSTEM USING GSM AND GPS” International Journal of Advanced Research Trends in Engineering And Technology (IJARTET), 2016 April.