

An Individually Personal Care Robot-Abettor

Uma Shankar Dash¹, Rudra Nandan Pramanik², Umakanta Barik³

¹Professor, ²Assistant Professor, ³Student

Department of Mechanical Engineering

Einstein Academy of Technology and Management

Bhubaneswar, Khurdha

Odisha, India

ABSTRACT

In the advanced world the Robot got moving in address the issues of individuals in various ways in various recorded of ventures and markets. Comparable way individuals will generally look for needing the robots in home to make it as their own help with help their works and they need it as their manual for clear the thoughts. They need individual robots to mind of the people in the home, they need it to educate and play with their kid. To meet this sort of requirements a few humanoid bots like Alto, Alpha, Nao and Azzimo are accessible on the lookout. Be that as it may, they will quite often be costlier thus they not accessible for all individuals. With the goal that we proposed a thought "ABETTOR" – a humanoid bot to do every one of the things for the home and care at the low gauge of cash. This paper primarily centered on fostering a humanoid robot which has capacity to do the human works and make their life in better manner, which is deliberately done to make a fast development. The Robot can distinguish countenances of the new individual and item, then, at that point, it ready to remember it. There are a few cycles used to distinguish face, here there the examples of face are gathered and prepared to identify the countenances. The robot needs to interface with the client with next to no latencies. The voice acknowledgment framework and the discourse motor need to import with the goal that the robot can ready to react the inquiries posed. The Robot has impact evasion framework it helps it to in an anticipated manner by keeping away from articles and people. The robot is self-adjusting since it is two wheeled robots so the soundness framework is additionally consolidated to keep away from the fall of robot.

Key words: Robot, interface, Image handling, voice acknowledgment, preparing

INTRODUCTION

A humanoid robot has multi-disciplinary functions that perform and most important part is construct the structure, model and here we developing humanoid structured robot having motions, sensing and able to interact with peoples. However, the robot has two wheels, instead of legs which become crucial part to be balanced. The Abettor robot is two wheeled, humanoid structured robot which has to interact with people by its motion and main idea is to give a personal assistance to user and taking care of child from dangerous situations. The robot can rotate up to 180 degrees so that it can get camera feed straight from the user. The raspberry pi and Arduino are used as a main controller to make the system stable. The object detections are also made by training the different types of objects. The expressions are also can be made through the OLED display to express emotions and data. The Objective of this research is the following.

- Face and Object identification and recognition.
- To avoid collision through ultrasonic and localization by area mapping.
- To interact with the humans with speech engines.
- To move in stable way by avoiding falling.

- To display the expression through OLED display

2. PROCESS

The Abettor is a humanoid type variant structured robot. It has some functional characteristic to move around and it has able to interact with people and detect people with face recognition. The aim is to build a robot which will as same as personal assistant and it have cognitive type function to understand the condition of the person by interaction and face detection.

2.1. Block Diagram

The Block diagram explains the flow of execution how the robot is operated.

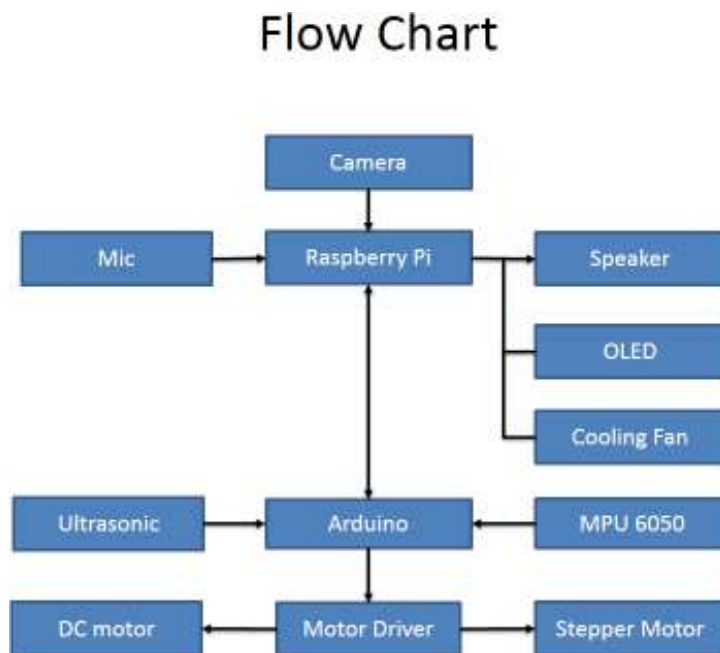

Figure2.1 Block of diagram

2.2. Face Detection

When the person is detected in the Robot vision it starts to draw a contour on the detected face and collect samples of the face in the separate folder with cropping function. The cropped pictures are stored in the np arrays in the form of 0's and 1's. So that every new face detected is stored in the separate array. The process is named as Local binary pattern histogram.

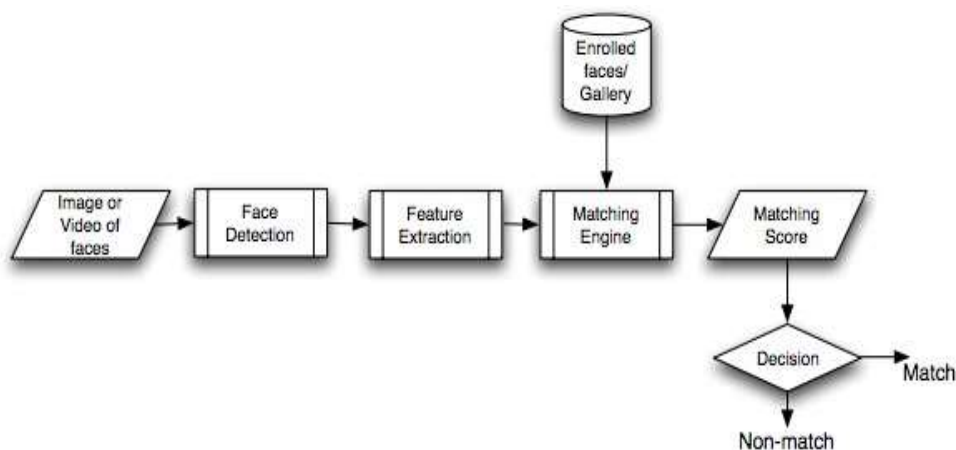

Figure2.2Facerecognition

To perform face recognition, we need to train a face recognizer, using a pre-labeled data set, Load the training images from data set folder, capture the faces and Id from the training images, put them in a list of Ids and Face Samples and return it. If the person face detected in vision whose data is already stored in the array, the robot will able to identify him and the details of the person are accessed which is already given by the user in first time. So, the person mail is signed in and mail can be sent to anyone by saying to recipient and the message. The program is done with helpofcv2 module available in python.

2.3. Voice Recognition

The microphone is attached to robot at its head part. The python script is done with help of pyttx and espeak module which is best for text to speech and Google API is used to convert speech to text. So, whenever the person speaks near to mic the voice is processed, where the espeak and pyttx helps to convert the speech to text and then texts are checked with code and corresponding output speech is heard in the speaker which is placed in the side of head. Since the microphone has low the sensitivity so the person has to come close to mic to communicate with the robot and the interactive session can be made where we have to use special engines to reply with whatever the questions are asked.

2.4. Self Balancing

The robot has two wheels which are responsible for stable movement of robot, the stability is attained by mpu6050 which is gyro and accelerometer sensor integrated. Gyro sensors, are devices that sense angular velocity also known as angular rate sensors or angular velocity sensors. The angular velocity is the change in rotational angle per unit of time and it expressed in degrees per second. Some accelerometers use the piezo-electric effects which contain microscopic crystal structures that get stressed by accelerative forces with which causes a voltage to be generated. Another way to do it is by sensing changes in capacitance.

The sensor is attached at the center axis of robot so that robot movement about the x-axis data is collected continuously by the Arduino and the code for each position of the robot axis is made. If the robot axis degree goes to 0 to 15 degrees [13] the corresponding function to make the base motor to rotate is made, thereby avoiding the falling of robot. There are modules and filters like Kalman which are used in program to get an accurate value on respecting axis without any noise.

2.5. Collision Avoidance

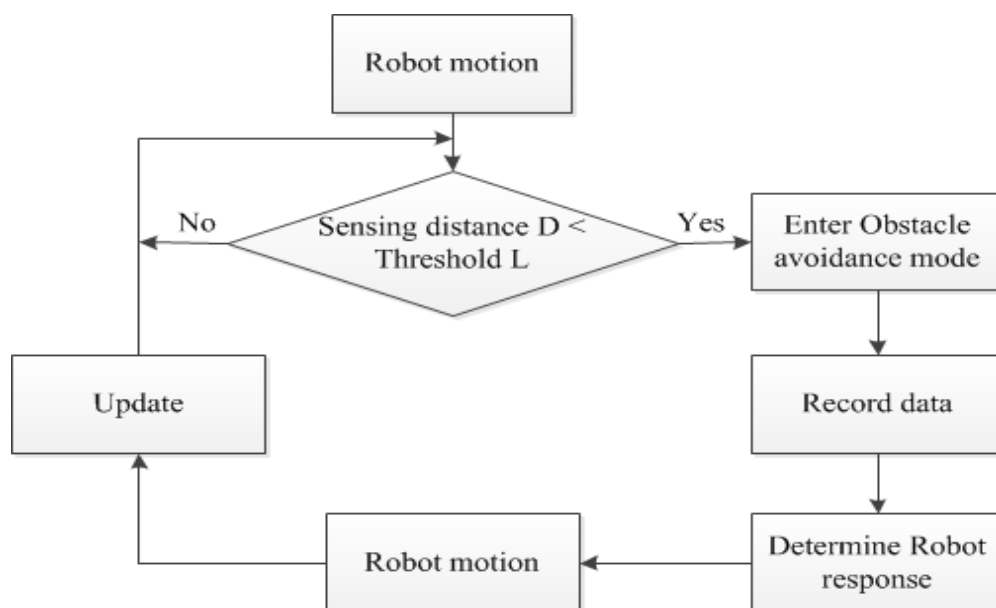

Figure2.3 Collision Flow Chart

The robot has the ultrasonic connected to three areas over the body, the codes are made so that the data from each sensor is calibrated and send data to the Arduino so that the range of below 15 cm can be detected has the object or interruption and signal made for base motor to stop is coded. The algorithm is written in such a manner that the robot can able to decide when to stop base motors. After the robot is stopped again the data is collected in loop so that further movement of robot is made. The voice data of “forward” commands and more which are written already in code are serially sent to the Arduino, so that the further movement can be started.

2.6. Display Expressions

The robot head has two OLED displays that are connected to raspberry pi, python has modules so that the expression can be coded. The loops are created for each and every expression that the robot can be look more realistic. The display works on I2C communication, every data that sent to display is printed in square box. The voice commands are also synced with program so that robot can do more expression and data can be also printed when some of the queries are asked.

2.7. Face Tracking

The stepper motor is connected to the Arduino, shaft of the motor is mounted with head part. The serial communication between raspberry pi and Arduino. The voice recognition, the face recognition and OLED are synced together as part of program that the robot can do rotation, expression and detection correspondingly. The head part can be rotated up to 180 degrees. If the person face is detected in the contour the head part is made to rotate on the same direction as the movement of person. And it able to detect the objects that are trained already.

2.8. Interaction

The Robot is programmed with basic set of responses so that it can be some to communicate with person in offline mode. With online mode, the pi is connected to Wi-Fi, so the interaction and queries can be made through Google api. When there is no internet, the robot can able to speak with certain set of responses which are programmed already like time, weather. These can be reprogrammed periodically through VNC server or other software's, so that responses can be added and changed to make the robot more interactive.

2.9. Design

The Robot is designed using Solid Works Software, the complete design is shown in below figure. The Robot is assembled by separate four parts [16]. The parts are Head, body, support, and base. The Extrude are made on the sizes of the components that are to be placed inside the robot. The base part has two motors, body part has the processors and the head part has the camera, speakers.

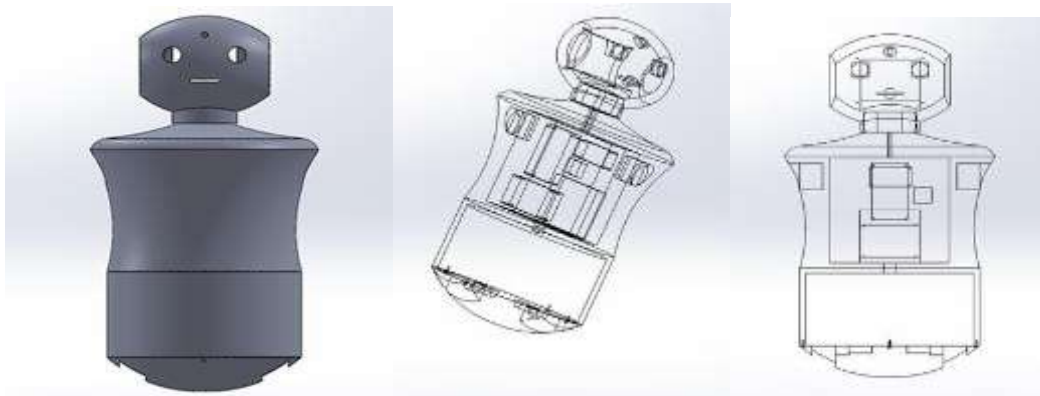

Figure2.4 Design

3. RESULTS

3.1. Results

The results obtained during Face detection and recognition are shown below. The data set is collected as YML file and trained using that.



Figure3.1 Collected Dataset

The contour is drawn on the detected face and name of the person when detected first is also printed on the screen. The data set collected during the detection is shown below. The Object can also be detected using the classifier which is in the form of .xml file. The trained

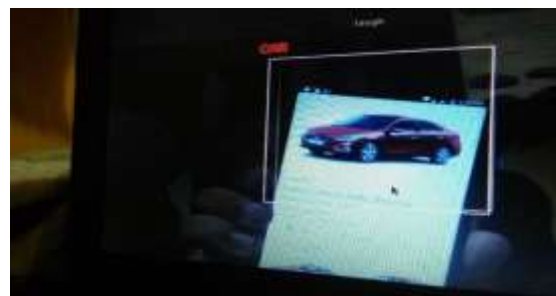

Figure3.3DetectedObject

form of data is stored in it. So the xml file is imported in program so that it can be accessed and processed to detect the type of objects.

It hardly takes half day to create a xml file of trained data set, where the more number of positive and negative samples are to be created, cropped and analyzed to create a .xml file.

There are also default haar classifiers available on the internet so that anyone can use the .xml file imported and can be used to detect objects like pen, mobiles, fruits etc.

3.2. Hardware



Figure3.4 Base of the Robot



Figure3.5 Base with support part

4. CONCLUSIONS

When the main program is started, the robot starts to stabilize itself by the values from the MPU, the base motors are controlled using the PWM. The robot will roam around the area without collision by using ultrasonics and object detections. The voice commands provided are making the bot to interact with people around and the movement to him is commanded by the voice commands. To make it our personal assistant we included the perception of sending mail to the person which the home person insists it send the mail by easy task by just recognize the face. The interactions are also made to the robot where basics of questions and reply's are preloaded. The head rotation of the robot is performed the camera feed where it draws a contour on the detect face and send data to the arduino serially so that the head of the robot can be moved to the side of the person. The Robot makes it movement by voice interactions which make the path trajectory for the movement . There are different types of process are to done to get a effective way to face recognition, the raspberry pi utilized to the main processing and incase of overheat it can able switch on the cooling fan which is also connected to the robot. The robot is can also able to charge itself with detecting the charging port and it now uses the lipo battery and power banks to run the whole system. The camera has inbuilt LDR so that the led get turn on when there is dark vision surrounding so that the robot can be able to do its tasks. The Speaker connected to the USB port which gives good sound when voices coming through espeak and also the language, the voice modulation also be altered as per our wishes. Ultimately the Robot now able to move in its path, by having its own data set and able to interact with humans.

REFERENCES

- [1] Kaneko K, Kanehiro F, Kajita S, Yokoyama K, Akachi K, Kawasaki T, Ota S, Iozumi T. Design of prototype humanoid robotics platform for HRP. In *Intelligent Robots and Systems*, 2002. IEEE/RSJ International Conference on 2002 (Vol. 3, pp. 2431-2436). IEEE.
- [2] Cannata G, Maggiali M, Metta G, Sandini G. An embedded artificial skin for humanoid robots. In *Multi sensor Fusion and Integration for Intelligent Systems*, 2008. MFI 2008. IEEE International Conference on 2008 Aug 20 (pp.434-438). IEEE.
- [3] Ambrose RO, Aldridge H, Askew RS, Burrige RR, Bluethmann W, Diftler M, Lovchik C, Magruder D, Rehnmark F. Robonaut: NASA's space humanoid. *IEEE Intelligent Systems and Their Applications*.2000Jul;15(4):57-63.
- [4] Hanson D. Exploring the aesthetic range for humanoid robots. In *Proceedings of the ICCS/CogSci-2006 long symposium: Toward social mechanisms of android science* 2006Jul 26(pp.39-42). Citeseer.
- [5] Yokoi K, Kanehiro F, Kaneko K, Fujiwara K, Kajita S, Hirukawa H. A honda humanoid robot controlled by aist software. In *Proc. of the IEEE-RAS International Conference on Humanoid Robots*2001 Nov(pp. 259-264).
- [6] Mizuuchi I, Nakanishi Y, Sodeyama Y, Namiki Y, Nishino T, Muramatsu N, Urata J,HongoK, YoshikaiT, In aba M. Anadvanced musculoskeletal humanoid kojiro.In *Humanoid Robots*, 2007 7th IEEE-RAS International Conference on 2007 Nov 29 (pp.294-299). IEEE.
- [7] Beira R, Lopes M, Praça M, Santos-Victor J, Bernardino A, Metta G, Becchi F, Saltarén R. Design of the robot-cub (icub) head. In *Robotics and Automation*, 2006. ICRA 2006. Proceedings 2006 IEEE International Conference on 2006 May15 (pp.94-100). IEEE.
- [8] Asfour, Tamim, et al. "ARMAR-III: An integrated humanoid platform for sensory-motorcontrol." *HumanoidRobots,20066thIEEE-ASInternationalConferenceon*.IEEE,2006.
- [9] Ogura, Yusuke, et al. "Development of a new humanoid robot WABIAN-2." *Robotics and Automation*, 2006. ICRA 2006. *Proceedings 2006 IEEE International Conference on*.

- IEEE, 2006.
- [10] Asfour, Tamim, Karsten Berns, and Rüdiger Dillmann. "The humanoid robot ARMAR: Design and control." *The 1st IEEE-RAS international conference on humanoid robots(humanoids 2000)*. 2000.
- [11] Park, Ill-Woo, et al. "Mechanical design of humanoid robot platform KHR-3 (KAIST humanoid robot3: HUBO)." *Humanoid Robots,2005 5th IEEE-RAS International Conference on*. IEEE, 2005.
- [12] Dario, Paolo, Eugenio Gugliel melli, and Cecilia Laschi. "Humanoids and personal robots: Design and experiments." *Journal of Field Robotics*18.12 (2001): 673-690.
- [13] Gouaillier, David, et al. "Mechatronic design of NAO humanoid." *Robotics and Automation, 2009. ICRA'09. IEEE International Conference on*. IEEE,2009.
- [14] Kagami, Satoshi, et al. "Design and implementation of software research platform for humanoid robotics: H6." *Robotics and Automation, 2001. Proceedings 2001 ICRA. IEEE International Conference on*. Vol. 3. IEEE, 2001.
- [15] Surdilovic, Dragoljub, et al. "Compliance control with dual-arm humanoid robots: Design, planning and programming." *Humanoid Robots (Humanoids),2010 10th IEEE-RAS International Conference on*. IEEE, 2010.
- [16] Tsagarakis, Nikos G., et al. "The design of the lower body of the compliant humanoid robot "cCub"." *Robotics and Automation (ICRA), 2011 IEEE International Conference on*. IEEE, 2011.
- [17] Rami Matarneh, Svitlana Maksymova, Zhanna Deinekoand Vyacheslav Lyashenko, Building RobotVoice Control Training Methodology Using Artificial Neural Net, *International Journal of Civil Engineering and Technology*, 8(10), 2017, pp.523–532
- [18] P.Kamal Kumar, Taj, L.Praveen, Anoop Joshi and G Musalaiah. Fabrication of Pneumatic Pick and Place Robot. *International Journal of Civil Engineering and Technology*, 8(7), 2017, pp.594–600.