

# DATA ACQUISITION SYSTEM WITH REMOTE ACCESSIBILITY

SK.JOHN SYDHA  
Research Scholar, Dept. Of E.C.E,  
Annamalai University,  
Email:johnsydha@gmail.com

Dr RAMESH BABU.K  
Prof., Dept.Of E.C.E  
Annamalai University,  
Email:rameshbabu.k@gmail.com

## ABSTRACT:

A Data acquisition plays an important role in real-time controls and online supervisions. System is required to be able to acquire, save, analyze, and process real time data. On-line interactive monitoring application is a challenging part of many embedded and real time data acquisition and control system applications. Different data acquisition systems measures different remote signals and control the remote devices through communication network. This review paper will focus on different published interactive embedded data acquisition systems.

## INTRODUCTION:

Now a days data acquisition system with remote accessibility is great in demand for various applications. The main aim behind building a remotely connected data acquisition system is to acquire the necessary data for user with correct speed and at a correct time, so that user can monitor recorded values from system. A client may also be able to find the problem and also control the situation. The information can easily be acquired and controlled by PC.

A Data Acquisition System is comprised of three parts; an input, output sub-system, a host computer and the controlling software. A Stand alone Linux application combine the input, output sub-system and the host CPU in the same package.

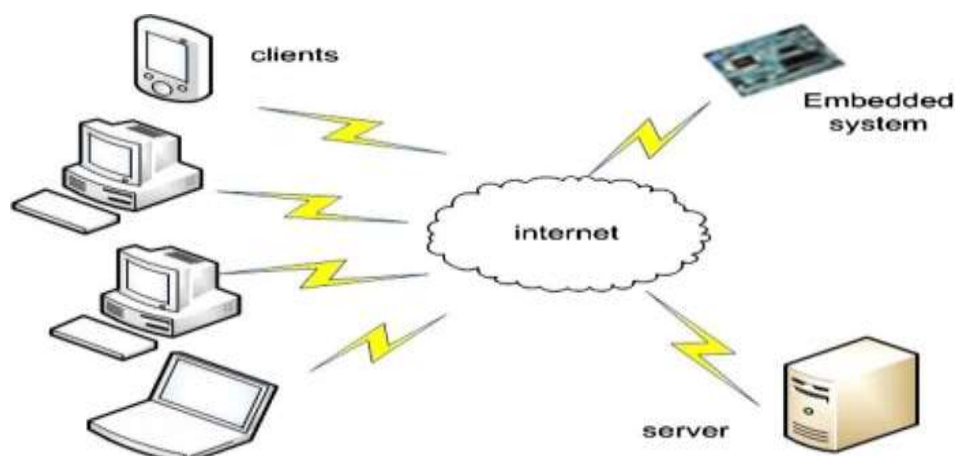

Fig -1: Interactive Data acquisition system

These systems are often referred to as embedded data acquisition. Interactive embedded based data

acquisition system is made up of three parts embedded system, server, client PC which are connected to each other through internet or Ethernet. The main core of data acquisition system is an embedded hardware. The embedded device communicates through General Packet Radio Service (GPRS) or Ethernet with other part of data acquisition system, because of which user can access it from anywhere in the world through a web server. Also, bidirectional data transfer is possible in real time for interaction in between. If user requires any data from embedded system, user can directly communicate with embedded system and will acquire required data. It reduces time taken for data transfer. Also user can interact with server. In some of these systems there is no need of server software and maintenance, because they are using web server for data storage and transfer. In this case a standard web browser is used by user or client to access required data.

The overall approach is introduces minimization of operational costs while operating with a large amount of data. The system is modularly built, allowing different modules to be added. In addition, it is flexible to accommodate a wide range of measurement devices with appropriate interfaces.

For Data management this type of system sends all the captured pictures through internet at the Internet server. If the huge data or big images has to be sent, the embedded module is set in such a way that it sends the image only once through GPRS and stores it on server. This way we eliminate transferring same data to each client through GPRS. This reduces quantity of data transfer. So, the transfer cost is reduced especially when more than one client requests for same data or there are multiple requests for the same data at a time.

### **Literature Survey:**

In This paper centre core of this system is ARM Processor running on real time operating system and web server application. Every data acquisition and control device contains 24-way acquisition and control channels and isolated from each other. Number of electrical and non electrical signals like current, voltage, resistance etc. can be selected by each I/O channel. ADC is used for analog to digital conversion of data. The measured and converted data is stored in external memory. This external memory behaves as a data base during web server mode. For communication in between Ethernet is used. The ARM processor directly supports RS485 communication. Data has been stored and controlled on some other PCs or network via RS485 & Ethernet. Web pages are written in Hypertext markup language.

This system is very useful in industry field as well as in Smart-house applications, networked lighting control system and other distributed control systems. This system has number of application in area of electric power, petroleum, chemical metallurgy, steel, transportation.

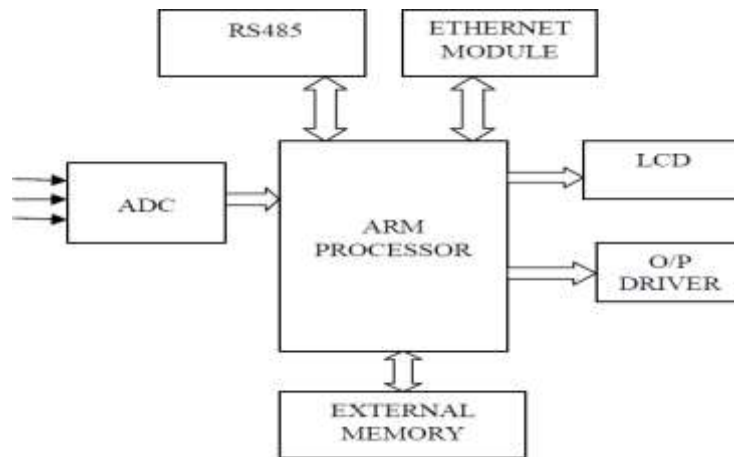

**Fig -2: Embedded web server for real time application**

On-line Interactive Data Acquisition and Control System for Embedded Real Time Applications. Hardware of this system consist of S3C2440 ARM9 processor with touch screen, serial port. Mini2440 which is known as friendly ARM is interfaced with touch screen for display as well as input and output. LM-35 temperature sensor is used for temperature monitoring. The Universal Asynchronous Receiver Transmitter is used for data Communication. Operating system used here is Linux. QTOPIA is used for application development. They used TCP/IP protocol for networking of PC. Interaction is done using Ethernet. RJ-45 connectors are used for Ethernet connection. Web pages are written by Hypertext markup language (HTML). For memory mini 2440 has two external SDRAM chips having 32 Mb for each and also flash memory which is used for system storage.

This system performs intelligent work for educational institutions, offices and many other places. This system gives a simple but enhanced and more powerful user interface without additional hardware, but it requires high response time because of poorly designed and configured software architectures.

Internet based data acquisition system using embedded Raspberry Pi processor for single chip method with GSM module for remote access. In this paper an embedded system integrates camera, GPS connected to Raspberry Pi for data acquisition. This embedded system is connected to via internet to user. On the user side there is a GSM module for connectivity. CMOS camera is used for capture images. For reception of GPS data they are using a micro strippatch antenna followed by a low noise amplifier with NMEA 0183 receiver protocol. Linux operating system is used in this system which is a good choice for embedded device. To download the hex file into the microcontroller board this system uses a programmer called flash magic tool. Keil ARM ( $\mu$ Vision)

is used for program development of embedded applications quickly and successfully. The protocol used for the communication between web server and web browser is Hyper Text Transfer Protocol or HTTP protocol.

This system is very useful for equipment maintenance and improves efficiency suited for industrial requirement for monitoring and controlling. It also provides real time remotely monitored and controlled solution for automation of industries. This system measures various remote signals and also controls different remote devices using internet connection. By using different customization this system will suit for number of industrial application related to data acquisition, monitoring and control.

## **CONCLUSION:**

This paper provides an overview for different data acquisition and control system in various applications. Literature survey provides detailed information about existing systems. There are many data acquisition and monitoring systems present in various areas. In this paper, from above literature survey it is clear that each data acquisition and monitoring has its own pros and cons. Many of them have used ARM 9 and ARM 11, in that raspberry pi is the latest one. Different techniques are used networking in that internet is most efficient technique for connectivity in between.

## **REFERENCES:**

- [1] Niturkar Priyanka R. and Prof. V. D. Shinde, "Embedded Web Server for Real Time Applications," IJECCE Vol. 5, Issue (4) July. 2014.
- [2] Priyanka Patil, Dr. Virendra V. Shete, Pranali Awate, "On-line Interactive Data Acquisition and Control System for Embedded Real Time Applications," IJAREEIE, Vol.4, Issue5, May 2015, doi:10.15662/ijareeie.2015.0405004.
- [3] Priti. G. Pachpande and S. P. Dhaniure, "Internet Based Data Acquisition Sytem," IJEECS, Volume -2, Issue-1, January, 2014.
- [4] Data acquisition handbook – A reference for DAQ and analog & digital signal conditioning, Measurement computing Corporation, USA, 3rd Edition, 2004-14
- [5] Principles of data acquisition and conversion, application bulletin, Burr Brown Corporation, USA, 1994