

## AUTOMATIC STREET LIGHT USING LDR AND IR

**Dr. Vinit Kumar Gunjan, Mr. D. Divya Priya, Mrs. B. Vinutha, Mrs. K. Persis,** CMR Institute of Technology Hyderabad

### **Abstract:**

Currently, street lights are operated manually. Additionally, these lights use a lot of power. Therefore, an automatic street light system is implemented to avoid this issue. Nowadays it is the most popular project. The main aim of this system is to save electricity. This system's two main components are LDR and IR. Street lights will automatically turn ON in the evening and switch off in the daytime with the use of LDRs (light dependent resistors). But using only LDR sensors has a drawback to the system because street light glows at night even when there are no vehicles on the road, wasting electricity. To avoid this issue an IR sensor is also used which detect the objects movement. Finally, by using these two sensors light glows when there is dark and object movement.

**Keywords:** Arduino UNO, LDR sensor, IR sensor, LED (Light emitting Diode), resistors.

### **Introduction**

In India 118 years ago, the first electricity street light was installed in Bangalore. Before the electricity street lights kerosene lamps are used. Present there are 35million street lights are installed in India. These street lights glow with high intensity even when there are no vehicles or human movements on the road and sometimes street light turn ON in the day time also, which leads to wastage of electricity. So, to avoid this problem an automated street light system is introduced. With the help of this system street lights are automatically ON/OFF without manpower. In this system LDR, IR, Arduino UNO, resistors and other components are used to make the light automatic. Unnecessarily using electricity means wasting natural resources like coal, natural gas and water etc. It is our responsibility to protect natural resources for future generations.

### **Literature Survey:**

1. Using a light-dependent resistor, Gauthami C. and her colleagues presented a paper on a self-operating street light control system in 2016. LDR and a microcontroller are used in the system they have developed. The street light system is controlled by the microprocessor, which acts as its brain. For developing the microcontroller's code, they used the C programming language.
2. Jagannath Dixit and his colleagues published a paper on Automatic Street light controller system using LDR and IR sensor. They used LDR and PIR sensors to automate the light .LDR sensor detect light and PIR sensor detects human movement. This proposed system is cost-effective and the safest way to reduce power consumption.
3. Prashant Kumar and his colleagues presented a paper on IOT based automatic street light control and fault detection. They used LDR, IR and GSM module to make the system more effective . If light fails to glow, the GSM module send message to respective authorized mobile number.

### **Proposed Methodology:**

In our Proposed method, Street lights are automatically ON/OFF without manpower. In this method LDR and IR sensors are used to automate the light. LDR sensor detects light and IR sensor detects object movement. LED lights are also used which helps to reduce the power consumption.

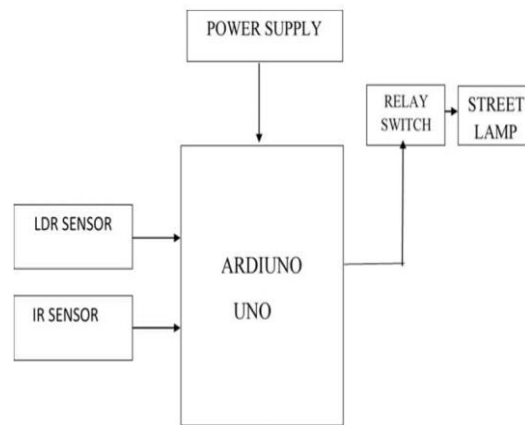

**Figure1:** Proposed System Architecture

Figure1 shows that LDR and IR sensors are connected to arduino. And Power supply is provided by power jack or USB cable. Relay switch automates street Lamp.

**List of components used**

- Arduino UNO
- LDR sensor
- IR sensor
- 10k resistor
- 9v power supply
- PCB board or Breadboard
- USB cable for Arduino
- Connecting wires

**Arduino UNO**

UNO is an Italian term which means one. Arduino UNO uses an ATmega328p microcontroller. Components of Arduino UNO are listed below:

- ATmega328p microcontroller
- Digital I/O pins
- Analog pins
- USB port
- Reset Button
- Crystal oscillator
- Voltage regulator
- Power jack

The heart of Arduino UNO is ATmega328p microcontroller. Digital and analog sensors are connected to their respective digital and analog pins. There are 14 digital I/O pins these are numbered from 0 to 13 and 6 analog pins from A0 to A5. With the help of USB port program is dump into the Arduino board. Reset button helps to run the program again from beginning. By using power jack 4v DC power supply is given to the arduino. And Voltage regulator converts 4v DC into 5v.

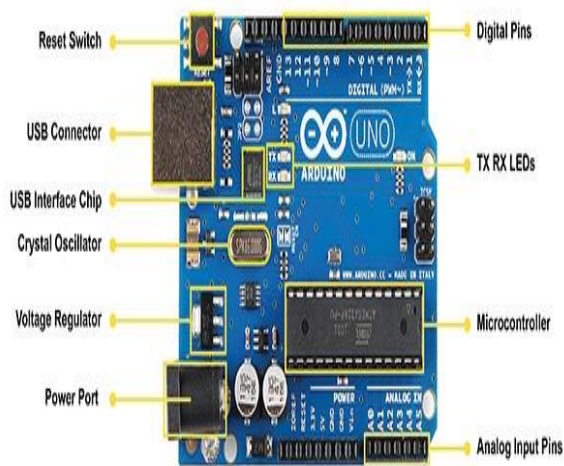

**Figure 2: Arduino UNO**

Figure 2 shows all the components of arduino

**LDR Sensor**

LDR is a type of resistor which depends on light so it is called as light dependent resistor. It is also called as photoresistor. It works on the principle of photoconductivity. When the intensity of light increases resistance of LDR decreases so, resistance of LDR depends on light. Figure 3 shows all components of LDR This sensor has 4 pins they are:

1. VCC
2. GND
3. D0
4. A0



**Figure 3: LDR Module**

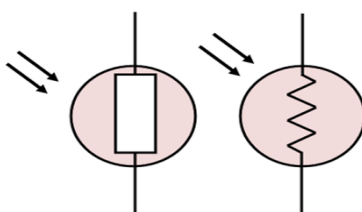
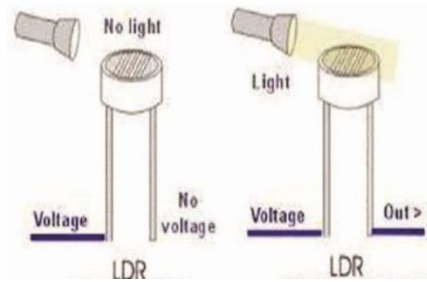

**Figure4: LDR Circuit Symbols**

Figure 4 shows LDR circuit symbols, above two symbols are used in the construction of circuit.

**Working of LDR**

When LDR senses Light then only voltage passes through the terminals or electrodes otherwise voltage doesn't pass through the terminals.

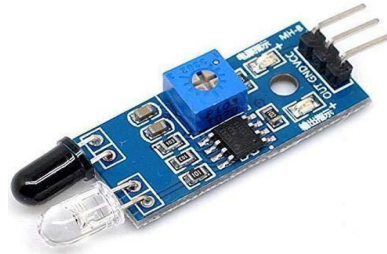

**Figure 5:** working of LDR  
Figure 5 shows working of LDR

**IR sensor**

Infrared sensor emits light in order to detect nearby objects in the environment. This sensor includes an IR emitter LED and an IR receiver. When an object comes near to this sensor light glows brightly otherwise light glows dim Figure5 shows all components of IR sensor. This sensor has 3 pins they are:

- 1.VCC
- 2.GND
- 3.OUT



**Figure 6:** IR Module

**Relay Switch**

Relays essentially function as open or closed valves that turn on or off when a current flows through their coil. Figure7 shows all components of relay switch.



**Figure7:**Relayswitch

**Flow Chart**

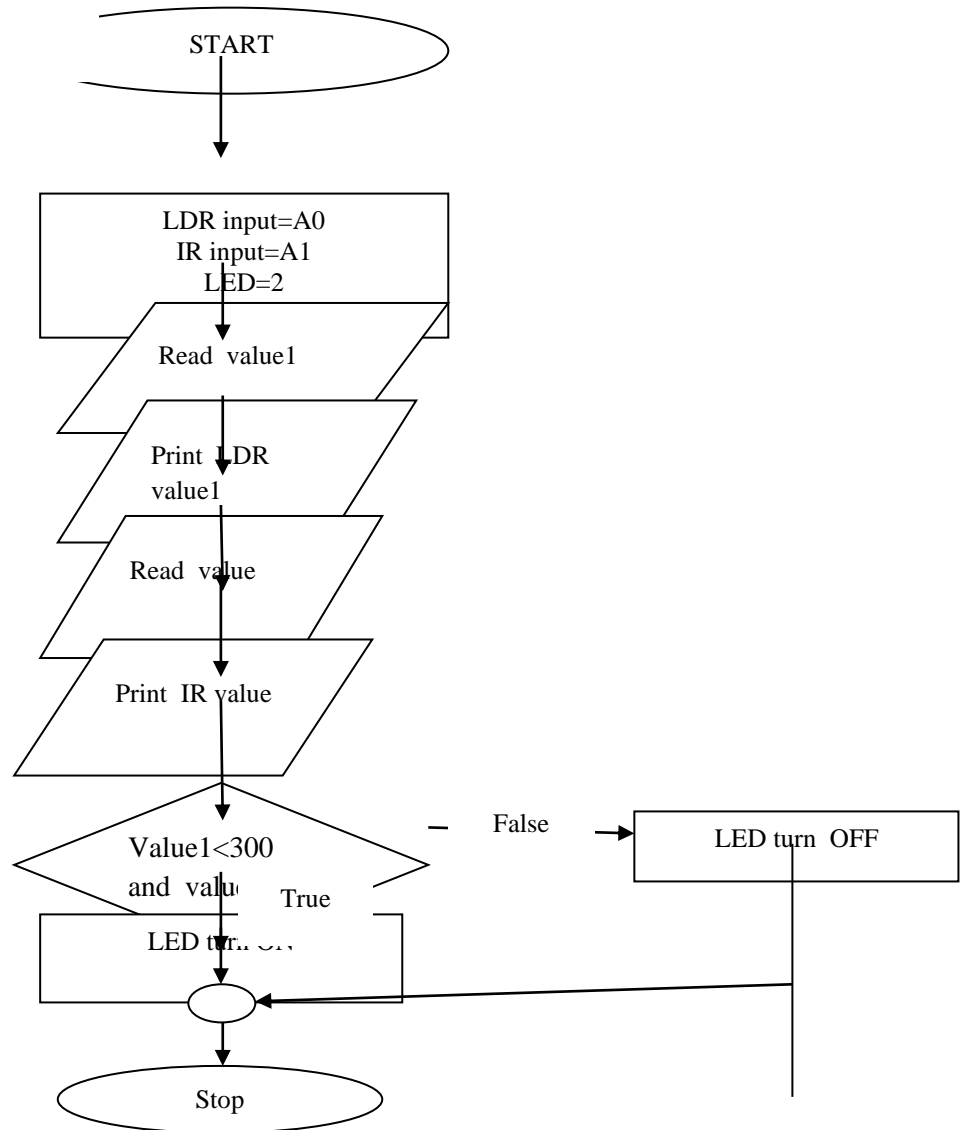

**RESULT**

As a result, this automated street light infrastructure is cost effective. The system does not require staff and by using this system electricity is also saved.

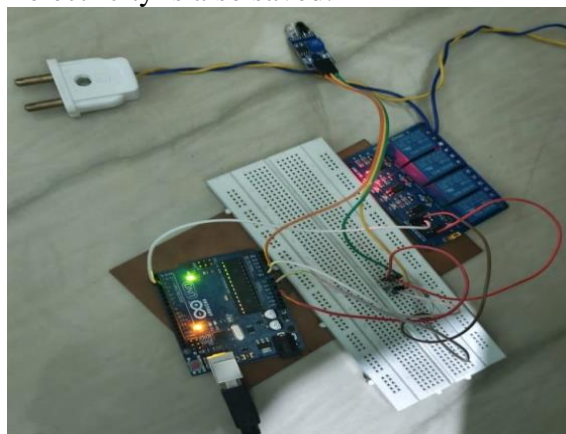

**Figure 8:** All components connected with breadboard

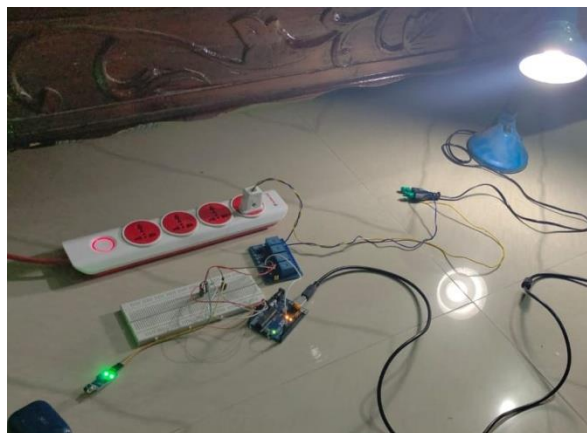

**Figure 9:** IR detects object and no light falls on LDR, Light glows.



**Figure 10:** IR detects object and light falls on LDR, light turn OFF.

## Conclusion

Arduino UNO was used to create a working prototype of automated street light system. In this system LDR and IR sensors are used, LED turn ON when there is dark and object's movement. Finally, by using this system electricity is saved and it completely removes manpower.

## References

- [1] Gouthami.C, Santosh.C, A. Pavan Kumar, Karthik.A,Ramya.K.R“Design and Implementation of Automatic Street Light Control System using Light Dependent Resistor.” International Journal of Engineering Trends and Technology (IJETT) – Volume 35 Number 10 - May 2016.
- [2] Jagannath Dixit, Dr. Devesh Katiyar,Mr. Gaurav Goel “AUTOMATIC STREET LIGHT CONTROLLER SYSTEM USING LDR AND PIR SENSOR.” International Journal of Creative Research Thoughts Volume 9, Issue 5 May 2021.
- [3] Shivam Verma, Prashant Choudhary, Raj Harsh, Lalit Kumar, Mahesh Kamthe “Smart Street Light Based on IR Sensor.” Volume 10 Issue No.5
- [4] Prashant Kumar, Shivaraj S Hiremath, G V Sandeep, Santosh kumar Javalagi, Dr. Venkata Siva Reddy “IOT based Automatic Street Light Control and Fault Detection.” Turkish Journal of Computer and Mathematics Education Vol.12 No.12 (2021).
- [5] G. S. C. Kumar, D. Prasad, V. S. Rao and N. R. Sai, "Utilization of Nominal Group Technique for Cloud Computing Risk Assessment and Evaluation in Healthcare," 2021 Third International Conference on Inventive Research in Computing Applications (ICIRCA), 2021, pp. 927-934, doi: 10.1109/ICIRCA51532.2021.9544895.
- [6] V. S. Rao, V. Mounika, N. R. Sai and G. S. C. Kumar, "Usage of Saliency Prior Maps for Detection of Salient Object Features," 2021 Fifth International Conference on I-SMAC (IoT in

Social, Mobile, Analytics and Cloud) (I-SMAC), 2021, pp. 819-825, doi: 10.1109/I-SMAC52330.2021.9640684

[7] N. R. Sai, G. S. C. Kumar, M. A. Safali and B. S. Chandana, "Detection System for the Network Data Security with a profound Deep learning approach," 2021 6th International Conference on Communication and Electronics Systems (ICCES), 2021, pp. 1026-1031, doi: 10.1109/ICCES51350.2021.9488967.

[8] S. Gorintla, B. A. Kumar, B. S. Chanadana, N. R. Sai and G. S. C. Kumar, "Deep-Learning-Based Intelligent PotholeEye+ Detection Pavement Distress Detection System," 2022 International Conference on Applied Artificial Intelligence and Computing (ICAAIC), 2022, pp. 1864-1869, doi: 10.1109/ICAAIC53929.2022.9792696